

UNITED STATES PATENT AND TRADEMARK OFFICE

BEFORE THE PATENT TRIAL AND APPEAL BOARD

APPLE INC.,
Petitioner,

v.

HAPTIC, INC.,
Patent Owner.

IPR2024-01476
Patent 9,996,738 B2

Before MIRIAM L. QUINN, CHRISTOPHER L. OGDEN, and
ANDREAS BALTATZIS, *Administrative Patent Judges*.

BALTATZIS, *Administrative Patent Judge*.

DECISION
Denying Institution of *Inter Partes* Review
35 U.S.C. § 314

I. INTRODUCTION

Apple Inc. (“Petitioner”) filed a Petition requesting an *inter partes* review of claims 3, 6, 7, 12, and 13 (the “challenged claims”) of U.S. Patent No. 9,996,738 B2 (Ex. 1001, “the ’738 patent”). Paper 3 (“Pet.”). Haptic, Inc. (“Patent Owner”) filed a Preliminary Response. Paper 8 (“Prelim. Resp.”).

Under 35 U.S.C. § 314(a), the Board “may not authorize an *inter partes* review to be instituted unless . . . the information presented in the petition . . . and any response . . . shows that there is a reasonable likelihood that the petitioner would prevail with respect to at least 1 of the claims challenged in the petition.” However, institution of *inter partes* review is discretionary. *See Harmonic Inc. v. Avid Tech., Inc.*, 815 F.3d 1356, 1367 (Fed. Cir. 2016) (“[T]he PTO is permitted, but never compelled, to institute an IPR proceeding.”). For the reasons stated below, we exercise our discretion not to institute an *inter partes* review.

II. BACKGROUND

A. *Real Parties in Interest*

Petitioner identifies itself as the real party in interest. Pet. 91. Patent Owner identifies itself as the real party in interest. Paper 6, 1 (Patent Owner’s Mandatory Notice).

B. *Related Matters*

The parties indicate that the ’738 patent is the subject of a co-pending civil litigation, *Haptic Inc. v. Apple Inc.*, No. 1:23-cv-01351 (W.D. Tex.), filed November 6, 2023, which has been transferred to the Northern District of California with case number 3:24-cv-02296-JSC. Pet. 91; Paper 6, 1.

Petitioner filed a separate petition (IPR2024-01475) challenging claims 1, 2, 4, 5, and 8–11 of the ’738 patent. Petitioner filed a Notice

Ranking the petitions, ranking the instant Petition (IPR2024-01476) second and the IPR2024-01475 petition first. *See* Paper 2. Because we deny institution in both proceedings, we do not address Petitioner’s ranking.

C. The '738 Patent (Ex. 1001)

The '738 patent relates to “a manual control system for a terminal device such as a television, lighting fixture, thermostat or laptop.” Ex. 1001, 1:40–42. More specifically, the '738 patent “relates to a control system on an exterior mounting surface independent from the terminal device to be controlled,” that detects gestures on the mounting surface and generates commands for the terminal device based on detected gestures. *Id.* at 1:42–48.

The '738 patent describes a control system comprising a housing engaged to a mounting surface, a sensor within the housing, a server in communication with the sensor, and a terminal device in communication with the server. *Id.* at 6:49–53, Fig. 1.

Figure 4 illustrates a side elevation view of an embodiment of the housing on a mounting surface and is reproduced below.

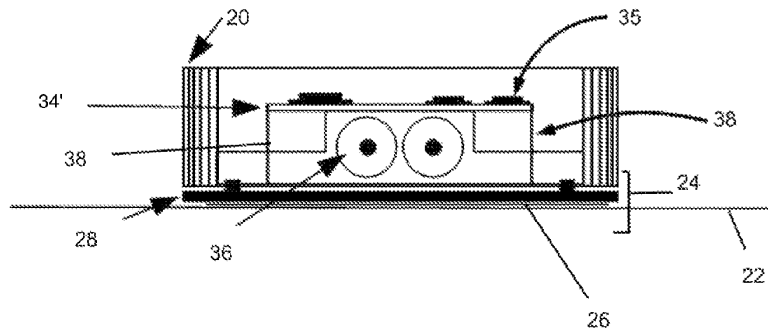

FIG. 4

Id. at 6:19–20. Figure 4 illustrates housing 20 comprised of engagement means 24 for mounting surface 22. *Id.* at 6:62–63. Engagement means 24 comprises attachment means 26 between housing 20 and mounting surface

22 and transmission portion 28 connecting sensor 30 to housing 20. *Id.* at 7:1–4. According to the '738 patent,

[t]he attachment means 26 can be an adhesive, mechanical fasteners, threaded screws or other components to hold the housing 20 to the mounting surface 22. In some embodiments, the transmission portion 28 can be comprised of frames and brackets 38 or a spring loaded portion (not shown) so as to reduce damping. There is a rigid positioning of the sensor 30 relative to the mounting surface 22 through the housing 20. Any sound or vibration of the mounting surface 22 is transmitted to the sensor 30. The engagement means 24 attaches the sensor 30 and reduces damping so that sensor 30 more accurately detects the mounting surface 22. The transmission portion 28 affects sound or vibration or other stimuli from the mounting surface 22 to the sensor 30.

Id. at 7:4–17.

D. Illustrative Claims

Petitioner challenges claims 3, 6, 7, 12, and 13 of the '738 patent. Pet. 1. Claims 3, 6, and 7 depend directly or indirectly from claim 1, and claims 12 and 13 depend directly or indirectly from claim 10. Claim 1 is illustrative of the challenged claims, and is reproduced below.¹

1. [1pre] A control system comprising:

[1a] a housing having an engagement means for a mounting surface;

[1b-i] a sensor contained within said housing, [1b-ii] said sensor forming an interactive zone defined by a range of said sensor, [1b-iii] said sensor being comprised of an accelerometer, [1b-iv] said interactive zone being aligned with said mounting surface and overlaying said mounting surface outside a perimeter of said housing, [1b-v] said sensor being in a fixed position relative to said

¹ We adopt Petitioner's bracketed identifiers.

engagement means, [1b-vi] wherein a contact interaction associated with said mounting surface within said interactive zone is detected by said sensor as data signals, [1b-vii] said contact interaction being comprised of an impact on said mounting surface, [1b-viii] said data signals being comprised of vibration data of said contact interaction;

[1c-i] a server in communication with said sensor, [1c-ii] said server being comprised of a routing module, [1c-iii] a processing module being connected to said routing module, and [1c-iv] an output module connected to said processing module, [1c-v] said routing module receiving said data signals from said sensor, [1c-vi] said processing module determining a data pattern corresponding to said data signals of said contact interaction and matching said data pattern with a gesture profile, said gesture profile being associated with a command; and

[1d-i] a terminal device [1d-ii] being comprised of a receiving module [1d-iii] and means for initiating activity of said terminal device corresponding to said command, [1d-iv] said terminal device being in communication with said server, [1d-v] said output module transmitting said command to said receiving module,

[1e] wherein said engagement means of said housing comprises:

an attachment means between said housing to said mounting surface; and

a transmission portion connecting said sensor to said attachment means of said housing and being comprised of a material with flexibility different than said mounting surface so as to set a rigid position of said sensor relative to said mounting surface, said contact interaction generating said data signals of said sensor through said transmission portion.

Ex. 1001, 12:2–45.

Claim 10 recites a method of controlling a terminal device using an apparatus similar to that of claim 1. *See id.* at 13:35–27.

E. Asserted Evidence

Petitioner relies on the following references in its asserted grounds of unpatentability:

Name	Reference	Ex. No.
Stewart	US 4,744,249	1006
Sachs	US 2009/0265671 A1	1007
Murakoshi	US 2014/0191963 A1	1004
Orr	US 2015/0348554 A1	1005

F. Asserted Grounds of Unpatentability

Petitioner asserts that claims 3, 6, 7, 12, and 13 of the '738 patent are unpatentable in view of the following grounds. Pet. 9–10.

Claim(s) Challenged	35 U.S.C. § ²	Reference(s)/Basis
3, 6, 7, 12, 13	103	Murakoshi, Stewart
3, 6, 7, 12, 13	103	Murakoshi, Stewart, Sachs
3, 6, 7, 12, 13	103	Murakoshi, Stewart, Sachs, Orr

Petitioner relies on the Declaration of Benjamin B. Bederson, Ph.D. (Ex. 1003) in support of its contentions. Patent Owner relies on the Declaration of Jason Janét, Ph.D. (Ex. 2001) in support of its Preliminary Response.

² The Leahy-Smith America Invents Act (“AIA”), Pub. L. No. 112–29, 125 Stat. 284 (2011), amended 35 U.S.C. §§ 102 and 103, was effective on March 16, 2013. The '738 patent claims priority to an application that has a filing date after March 16, 2013. *See* Ex. 1001, codes (22), (60). Thus, for purposes of this Decision, we apply the AIA versions of §§ 102 and 103.

III. DISCRETIONARY DENIAL

Patent Owner argues that we should exercise discretion to deny institution under 35 U.S.C. § 314(a) because the factors identified in *Apple Inc. v. Fintiv, Inc.*, IPR2020-00019, Paper 11 (PTAB Mar. 20, 2020) (precedential) (“*Fintiv*”), weigh in favor of denying institution. Prelim. Resp. 41–45. Petitioner argues we should not discretionarily deny institution under 35 U.S.C. § 314(a). Pet. 90. For the reasons below, we agree with Patent Owner and exercise our discretion to deny institution.

Under Section 314(a), the Director has discretion to deny institution. *See* 35 U.S.C. § 314(a) (stating “[t]he Director may not authorize an inter partes review to be instituted unless the Director determines that the information presented in the petition . . . shows that there is a reasonable likelihood that the petitioner would prevail with respect to at least 1 of the claims challenged in the petition”); *SAS Inst. Inc. v. Iancu*, 138 S. Ct. 1348, 1356 (2018) (“[Section] 314(a) invests the Director with discretion on the question whether to institute review.” (emphasis omitted)); *Cuozzo Speed Techs., LLC v. Lee*, 136 S. Ct. 2131, 2140 (2016) (“[T]he agency’s decision to deny a petition is a matter committed to the Patent Office’s discretion.”); *Harmonic Inc.*, 815 F.3d at 1367 (“[T]he PTO is permitted, but never compelled, to institute an IPR proceeding.”).

In determining whether to exercise this discretion based on a related litigation, the Board assesses all relevant circumstances, including the merits, to balance considerations such as system efficiency, fairness, and patent quality. *See Fintiv*, Paper 11; *NHK Spring Co. v. Intri-Plex Techs., Inc.*, IPR2018-00752, Paper 8 at 19–20 (PTAB Sept. 12, 2018) (precedential). We consider six factors as part of this balanced assessment when determining whether to use our discretion to deny institution:

1. whether the court granted a stay or evidence exists that one may be granted if a proceeding is instituted;
2. proximity of the court's trial date to the Board's projected statutory deadline for a final written decision;
3. investment in the parallel proceeding by the court and the parties;
4. overlap between issues raised in the petition and in the parallel proceeding;
5. whether the petitioner and the defendant in the parallel proceeding are the same party; and
6. other circumstances that impact the Board's exercise of discretion, including the merits.

Fintiv, Paper 11 at 5–6. In evaluating these factors, we “take[] a holistic view of whether efficiency and integrity of the system are best served by denying or instituting review.” *Id.* at 6.

1. *Stay in the Parallel Proceeding (Factor 1)*

Under the first *Fintiv* factor, we consider “whether the court granted a stay or evidence exists that one may be granted if a proceeding is instituted.” *Fintiv*, Paper 11 at 6. Patent Owner contends that this factor weighs in favor of denial because the District Court denied Petitioner's motion for stay on November 20, 2024. Prelim. Resp. 42.³ Patent Owner acknowledges that “the court denied the motion without prejudice,” but argues that the District Court's decision appears unlikely to change. *Id.* As support, Patent Owner cites to the District Court's findings in denying the stay, namely, that (1) the litigation had progressed significantly with a trial date scheduled prior to the

³ Petitioner indicates no stay was requested at the time of filing the Petition. *See* Pet. 90.

Board’s projected final written decision and (2) a stay would prejudice Patent Owner. *See id.* (citing Ex. 2023, 3–6).

The District Court denied Petitioner’s “motion to stay without prejudice to renewal if the PTAB institutes IPR review.” Ex. 2023, 6. A stay denial without prejudice to renew if a PTAB trial is instituted “usually weigh[s] against exercising authority to deny institution.” *Fintiv*, Paper 11 at 7. But “proximity of the court’s trial date and investment of time are relevant to how much weight to give to the court’s willingness to reconsider a stay.” *Id.*

Although the District Court denied a stay pending the Board’s decision, the court also identified the proximity of the trial date and litigation investment as significant factors in its initial denial of the requested stay. *See* Ex. 2023, 6. Thus the evidence is inconclusive as to whether or not the District Court would stay the case if we granted institution at this time. Absent a clear indication from the District Court, we decline to predict whether a stay would be granted.

Accordingly, factor 1 is neutral.

2. *Proximity of Trial Date to Projected Deadline (Factor 2)*

Under the second *Fintiv* factor, we consider the “proximity of the court’s trial date to the Board’s projected statutory deadline for a final written decision.” *Fintiv*, Paper 11 at 6. Patent Owner states that the trial date in the parallel litigation is set for September 29, 2025, “over six months before the deadline for a final written decision here (April 10, 2026).” Prelim. Resp. 42 (citing Ex. 2023, 2; Ex. 2024, 2). Petitioner argues that this date is likely to change, citing the median time-to-trial of 48.9 months in the Northern District of California, which would push the trial date to December 2027. Pet. 90 (citing Ex. 1103, 66; Ex. 1102, 8). Patent Owner acknowledges

the potential for delay due to the current median time-to-trial in the district⁴, but argues that the advanced state of the litigation and the presiding judge’s reliance on the trial date in denying the stay means that the trial date is unlikely to be significantly delayed. Prelim. Resp. 42–44.

We weigh the evidence of the advanced state of the litigation and the presiding judge’s reliance on the scheduled trial date in denying the stay against the median time-to-trial statistics. *See Exs. 2023, 2024*. We also consider Petitioner’s submission of the scheduled and actual trial dates before the presiding judge. *See Ex. 1106*. As Patent Owner argues, the comparison of scheduled and actual trial dates does not show a consistent pattern of delay. *See Prelim. Resp. 43* (arguing that out of six cases “one had zero delay, one had a 21-day delay, and one had a 91-day delay, with an average delay of 192 days”). Of the evidence before us, only the median time-to-trial date indicates that the trial will be significantly delayed, which we find less persuasive than the presiding judge’s comments on the litigation. Taken as a whole, the evidence indicates that the District Court trial is likely to take place before a final written decision would be entered in this proceeding.

Accordingly, factor 2 weighs in favor of exercising discretion to deny institution.

3. *Investment in the Parallel Proceeding (Factor 3)*

Under the third *Fintiv* factor, we consider “the amount and type of work already completed in the parallel litigation by the court and the parties

⁴ Patent Owner cites a median time-to-trial of 47.9 months. Prelim. Resp. 42–43 (citing Ex. 2025, 66).

at the time of the institution decision” and the timing of the petition. *Fintiv*, Paper 11 at 9–12.

Petitioner argues that this factor favors institution because the Petition was filed “ahead of the one-year time bar” and “[s]ignificant resources on invalidity had not been expended.” Pet. 90.

Patent Owner argues that there has been significant investment in the parallel litigation. Prelim. Resp. 44. For example, Patent Owner argues that the “*Markman* hearing occurred on schedule on December 6.” *Id.* (citing Ex. 2023, 2; Ex. 2024, 1). Following the *Markman* hearing, the court issued its Claim Construction Order on January 13, 2025. Ex. 2028. Patent Owner further argues that “[b]y the institution deadline, the parties will have completed fact discovery and exchanged opening expert reports.” *Id.* (citing Ex. 2024, 1).

We find that the District Court and the parties have invested substantially in the merits of the invalidity position. *Apple Inc. v. Fintiv, Inc.*, IPR2020-00019, Paper 15 (May 13, 2020) (informative) at 14. Similar to *Fintiv*, the District Court issued a detailed 27-page claim construction order construing several claim terms. *See* Ex. 2028; *see Fintiv*, Paper 15 at 13–14. Unlike *Fintiv*, the parties here have invested more effort in the trial as fact discovery will be completed about the time of the institution decision. *See* Ex. 2024; *see Fintiv*, Paper 15 at 14 (“We recognize that much work remains in this case as it relates to invalidity: fact discovery is in its early stages, with document production ongoing and depositions just getting underway, expert reports are not yet due, and substantive motion practice is yet to come.”).

Based on the level of investment and effort already expended on claim construction and fact discovery in the District Court, factor 3 weighs in favor of exercising discretion to deny institution.

4. *Overlap of Issues (Factor 4)*

Under the fourth *Fintiv* factor, we consider “overlap between issues raised in the petition and in the parallel proceeding.” *Fintiv*, Paper 11 at 12. Petitioner stipulates that if we institute trial, Petitioner “agrees not to pursue for the instituted claims any grounds raised in the IPR, any grounds raised within [Petitioner’s] invalidity contentions that were raised or could have been raised in the IPR, or any grounds [Petitioner] could have reasonably raised.” Ex. 1110 (Letter of Stipulation) (citing *Sotera Wireless, Inc. v. Masimo Corp.*, IPR2020-01019, Paper 12 (PTAB Dec. 1, 2020) (precedential)). Petitioner’s broad stipulation mitigates certain concerns of duplicative efforts between the District Court and the Board, as well as concerns of potentially conflicting decisions. *Sotera*, Paper 12 at 19.

Thus, factor 4 weighs strongly in favor of not exercising discretion to deny institution.

5. *Identity of Parties (Factor 5)*

Under the fifth *Fintiv* factor, we consider “whether the petitioner and the defendant in the parallel proceeding are the same party.” *Fintiv*, Paper 11 at 13. Patent Owner asserts that denying institution is supported because the same parties are involved in both the present proceeding and the parallel litigation. Prelim. Resp. 45.

We agree that the same parties are involved. Accordingly, factor 5 weighs in favor exercising discretion to deny institution. *See Sotera*, Paper 12 at 19.

6. *Other Circumstances Including the Merits (Factor 6)*

Under the sixth *Fintiv* factor, we consider “other circumstances that impact the Board’s exercise of discretion, including the merits.” *Fintiv*, Paper 11 at 14. “For example, if the merits of a ground raised in the petition seem particularly strong on the preliminary record, this fact has favored institution.” *Id.* at 14–15. “By contrast, if the merits of the grounds raised in the petition are a closer call, then that fact has favored denying institution when other factors favoring denial are present.” *Id.* at 15.

Petitioner asserts “the Petition’s merits are compelling,” thus favoring institution. Pet. 90. Patent Owner asserts that the Petition’s challenges do not present a compelling challenge, Prelim. Resp. 45. We address the strengths and weaknesses of the merits below. *See Fintiv*, Paper 15 at 15 (“A full merits analysis is not necessary as part of deciding whether to exercise discretion not to institute, but rather the parties may point out, as part of the factor-based analysis, particular ‘strengths or weaknesses’ to aid the Board in deciding whether the merits tip the balance.”).

Petitioner relies on the combination of Murakoshi and Stewart to challenge independent claims 1 and 10. *See* Pet. 10–53. Patent Owner argues that Petitioner’s reasons to combine Murakoshi and Stewart lack support and that Petitioner has not shown a reasonable expectation of success in the combination. *See* Prelim. Resp. 19–36. We agree with Patent Owner that there are significant weaknesses in Petitioner’s arguments for combining Murakoshi and Stewart.

Murakoshi describes a housing containing a sensor for measuring vibrations on a surface and using the vibrations to generate a control signal for a device. Ex. 1004 ¶¶ 21, 25, 29, 30, 36. To measure vibrations on a surface, Murakoshi’s sensor must be fixed within the housing and held in

position relative to the surface. *See* Ex. 1003 ¶¶ 139 (“it is necessary to hold a sensor in a fixed position relative to a sensing surface to provide a fixed reference point for accurate detection of vibratory signals”), 171 (“the sensor is held in a particular position within the housing and relative to the surface that the housing is mounted to”). Stewart teaches the opposite: a sensor that is vibrated inside a housing to measure rotational movement. Ex. 1006, 5:54–56, 6:5–10, 6:20–31; Ex. 2001 ¶¶ 100, 133, 138. Thus, Stewart’s sensor is flexibly suspended with brackets inside the housing to allow movement and minimize transmission of vibrations from the surface to the sensor. Ex. 1006, 5:7–24, 7:61–64; Ex. 2001 ¶ 102.

Petitioner combines Murakoshi with Stewart’s brackets and case mounts to fix the sensor to prevent it from moving within the housing and thus enable the sensor to detect vibrations from outside the housing. *See* Pet. 24, 33–36. But Stewart’s teachings undermine the very reason proffered by Petitioner, because Stewart’s sensor is movably suspended within the housing so that it does not detect vibrations from outside the housing. *See DePuy Spine, Inc. v. Medtronic Sofamor Danek, Inc.*, 567 F.3d 1314, 1326 (Fed. Cir. 2009) (“An inference of nonobviousness is especially strong where the prior art’s teachings undermine the very reason being proffered as to why a person of ordinary skill would have combined the known elements.”).

Likewise, we find a significant weakness in Petitioner’s argument for a reasonable expectation of success in the combination. “The reasonable expectation of success requirement refers to the likelihood of success in combining references to meet the limitations of the claimed invention.” *Intelligent Bio-Sys., Inc. v. Illumina Cambridge Ltd.*, 821 F.3d 1359, 1367 (Fed. Cir. 2016). Claim 1 requires “said sensor being in a fixed position

relative to said engagement means” (limitation 1b-v) and “a transmission portion” that “set[s] a rigid position of said sensor relative to said mounting surface” (limitation 1e). As discussed above, neither Murakoshi nor Stewart appear to teach a sensor in a fixed position relative to said engagement means or a rigid position relative to said mounting portion. Accordingly, even if Murakoshi’s and Stewart’s teachings were to be combined, the combined teachings would not appear to meet the limitations of the claimed invention.

Taken as a whole, we cannot conclude that the Petition presents particularly strong merits. Therefore, this factor weighs in favor of exercising discretion to deny institution in a balanced assessment of all the circumstances. *See Fintiv*, Paper 15 at 17.

7. *Balancing the Fintiv Factors*

A holistic balancing of the *Fintiv* factors weighs in favor of discretionary denial. As discussed above, factors 2, 3, and 5 weigh in favor exercising our discretion to deny institution; the District Court trial is scheduled to begin six months before we would reach a final decision in this proceeding, the District Court has expended effort resolving substantive issues in the case, and the defendant in District Court and the Petitioner here are the same party. Factor 4 weighs strongly in favor of not exercising discretion to deny institution because Petitioner has provided a broad stipulation to avoid overlap between the District Court and the Board if this proceeding is instituted. Finally, under factor 6, we have determined that the merits are not particularly strong. A balanced assessment of all the factors together leads us to exercise our discretion to deny institution of an *inter partes* review.

IV. CONCLUSION

Based on the circumstances discussed above, we agree with Patent Owner that instituting a trial would be an inefficient use of Board resources. Thus, we exercise our discretion to deny institution under § 314(a).

V. ORDER

In consideration of the foregoing, it is hereby:

ORDERED that the Petition is denied; and

FURTHER ORDERED that no *inter partes* review is instituted.

IPR2024-01476
Patent 9,996,738 B2

FOR PETITIONER:

W. Karl Renner
Jennifer Huang
Kiersten Batzli
FISH & RICHARDSON P.C.
axf-ptab@fr.com
jhuang@fr.com
batzli@fr.com

FOR PATENT OWNER:

James Hall
Stephen Zinda
CABELLO HALL ZINDA, PLLC
james@chzfirm.com
stephen@chzfirm.com