

2017 WL 6613262

Only the Westlaw citation is currently available.

United States Court of Appeals,
Federal Circuit.

MICROSOFT CORPORATION, Appellant

v.

BISCOTTI, INC., Appellee

2016-2080

|

2016-2082

|

2016-2083

|

Decided: December 28, 2017

Synopsis

Background: Alleged infringer commenced inter partes review (IPR) proceedings challenging claims in patent relating to real-time video conferencing. The United States Patent and Trademark Office, Patent Trial and Appeal Board, Nos. IPR2014-01457, IPR2014-01458, IPR2014-01459, ruled that alleged infringer failed to establish that claims were anticipated or obvious, and alleged infringer appealed.

Holdings: The Court of Appeals, O'Malley, Circuit Judge, held that:

- [1] Board applied proper legal standard for anticipation;
- [2] substantial evidence supported Board's conclusion that alleged infringer failed to demonstrate that prior art reference anticipated claim requiring that video communication device include storage medium;
- [3] alleged infringer waived argument that claim was anticipated by prior art reference;
- [4] substantial evidence supported Board's conclusion that alleged infringer failed to demonstrate that prior art reference anticipated claim relating to set-top box; and
- [5] Board's determination was not undermined by its purportedly incorrect construction of "set-top box."

Affirmed.

[Newman](#), Circuit Judge, dissented and filed opinion.

West Headnotes (15)

[1] Patents [Questions of law or fact](#)**Patents** [Novelty;anticipation](#)

Anticipation is question of fact subject to substantial evidence review. [35 U.S.C.A. § 102](#).

[Cases that cite this headnote](#)**[2] Patents** [Construction and Operation of Patents](#)

Court of Appeals reviews de novo ultimate construction of patent claim, as well as any claim construction relying only on intrinsic evidence.

[Cases that cite this headnote](#)**[3] Patents** [Scope of Review](#)

In reviewing claim construction by Patent Trial and Appeal Board (PTAB) in inter partes review (IPR) proceeding, subsidiary factual findings based on extrinsic evidence, if any, are reviewed for substantial evidence.

[Cases that cite this headnote](#)**[4] Patents** [Language of claims in general](#)

Unexpired patent claims subject to inter partes review (IPR) are to be given their broadest reasonable construction.

[Cases that cite this headnote](#)**[5] Patents**

🔑 [Prior Art and Relation of Claimed](#)

[Invention Thereto](#)

Patents

🔑 [Prior Description in Printed Publication](#)

Patent is invalid as anticipated if invention was described in patent or published application before invention by patentee. [35 U.S.C.A. § 102\(e\)](#).

[Cases that cite this headnote](#)

[6] Patents

🔑 [Enablement](#)

Reference can anticipate patent claim, even if it does not expressly spell out all limitations arranged or combined as in claim, if person of skill in art, reading reference, would at once envisage claimed arrangement or combination. [35 U.S.C.A. § 102](#).

[Cases that cite this headnote](#)

[7] Patents

🔑 [Single reference disclosing every element or limitation of claim](#)

Prior art reference must provide every element of claimed invention arranged as in claim in order to anticipate, but claim does not need to expressly spell out all limitations combined as in claim if person of ordinary skill in art (POSA) would at once envisage arrangement or combination. [35 U.S.C.A. § 102](#).

[Cases that cite this headnote](#)

[8] Patents

🔑 [Number of Prior Art References; Combinations](#)

Anticipation is not proven by multiple, distinct teachings that artisan might somehow combine to achieve claimed invention. [35 U.S.C.A. § 102](#).

[Cases that cite this headnote](#)

[9] Patents

🔑 [Television and motion pictures](#)

Patent Trial and Appeal Board applied proper legal standard for anticipation in inter partes review (IPR) proceedings challenging claims in patent relating to real-time video conferencing, despite language indicating that prior art claims had to be identical to anticipate invention, where Board did not require word-for-word similarity or perfection, but explicitly considered whether person of ordinary skill in art (POSA) would at once envisage combination of claimed invention given prior art's disconnected teachings. [35 U.S.C.A. § 102](#).

[Cases that cite this headnote](#)

[10] Patents

🔑 [Television and motion pictures](#)

Substantial evidence supported finding that prior art reference did not anticipate claim in patent relating to real-time video conferencing requiring that video communication device include storage medium, even though prior art stated that “[e]mbodiments of a subset or all (and portions or all) of the above may be implemented by program instructions stored in a memory medium or carrier medium and executed by a processor,” where program-instructions sentence did not clearly link storage medium with all of prior art's embodiments, did not refer back specifically to various other disclosures, and could reasonably be read as referring only to embodiment depicted in figure immediately above it, and prior art's alleged disclosures of storage medium with instructions in accordance with limitations of patent claim were unrelated to each other in disclosure. [35 U.S.C.A. § 102](#).

[Cases that cite this headnote](#)

[11] Patents

🔑 [Judicial Review or Intervention](#)

Alleged infringer waived argument that claim in patent relating to real-time video conferencing teaching limitation requiring that invention receive “on the audiovisual

input interface, a set-top box audiovisual stream from a set-top box, the set-top box audiovisual stream comprising a set-top box video stream and a set-top box audio stream” was anticipated by prior art reference teaching about external codec with audio and video inputs coupled to and receiving audiovisual signals from television set-top box because interface described on one figure in prior art provided detailed view of audiovisual input interface for embodiment of external codec, where alleged infringer's petition to institute inter partes review (IPR) proceeding and its expert report before Patent Trial and Appeal Board referred only to other figures in prior art, and provided no information or argument as to how interface of figure allowed for connection to set-top box or how person of ordinary skill in art (POSA) would understand to use codec described in that figure along with figureless description of codec that could be used in independent housing and coupled to set-top box. 35 U.S.C.A. § 102; 37 C.F.R. § 42.104(b)(5).

[Cases that cite this headnote](#)

[12] Patents

[Television and motion pictures](#)

Substantial evidence supported finding that prior art reference did not anticipate claim in patent relating to real-time video conferencing requiring that claimed invention receive “on the audiovisual input interface, a set-top box audiovisual stream from a set-top box, the set-top box audiovisual stream comprising a set-top box video stream and a set-top box audio stream,” where alleged infringer failed to provide direct link in prior art to connect descriptions of codec with inputs in set-top box or to explain how interface would be compatible with set-top box and codec described in prior art, and there was no disclosure of audio input interface for set-top box. 35 U.S.C.A. § 102.

[Cases that cite this headnote](#)

[13] Patents

[Television and motion pictures](#)

Patent Trial and Appeal Board's finding that patent relating to real-time video conferencing was not anticipated by prior art reference was not undermined by its purportedly incorrect construction of “set-top box,” despite alleged infringer's contention that prior art's use of computer fell within patent's definition of “set-top box,” where alleged infringer failed to explain how computer would receive broadcast, cable, or satellite television signals, as required by patent, and Board's decision hinged on factors that were not affected by allegedly erroneous construction of “set-top box.” 35 U.S.C.A. § 102.

[Cases that cite this headnote](#)

[14] Patents

[In general;utility](#)

US Patent 7,907,164. Cited as Prior Art.

[Cases that cite this headnote](#)

[15] Patents

[In general;utility](#)

US Patent 8,144,182. Construed and Valid.

[Cases that cite this headnote](#)

Appeals from the United States Patent and Trademark Office, Patent Trial and Appeal Board in Nos. IPR2014-01457, IPR2014-01458, IPR2014-01459.

Attorneys and Law Firms

CONSTANTINE L. TRELA, Jr., Sidley Austin LLP, Chicago, IL, argued for appellant. Also represented by RICHARD ALAN CEDEROTH, DOUGLAS LEWIS; JOSHUA JOHN FOUGERE, JOSEPH A. MICALLEF, Washington, DC.

JOHN C. O'QUINN, Kirkland & Ellis LLP, Washington, DC, argued for appellee. Also represented by WILLIAM H. BURGESS; ADAM R. ALPER, San Francisco, CA; MICHAEL W. DE VRIES, Los Angeles, CA; AMANDA J. HOLLIS, Chicago, IL.

Before [Newman](#), [O'Malley](#), and [Reyna](#), Circuit Judges.

Opinion

Dissenting opinion filed by Circuit Judge [Newman](#).

*1 [O'Malley](#), Circuit Judge.

Microsoft Corporation (“Microsoft”) appeals from decisions of the Patent Trial and Appeal Board (“Board”) in three separate *inter partes* review (“IPR”) proceedings, in which the Board found that Microsoft failed to show by a preponderance of the evidence that the challenged claims of [U.S. Patent No. 8,144,182](#) (“’182 patent”) were anticipated or obvious. See *Microsoft Corp. v. Biscotti Inc.*, No. IPR2014–01457, 2016 WL 1084760, 2016 Pat. App. LEXIS 7571 (P.T.A.B. Mar. 17, 2016); *Microsoft Corp. v. Biscotti Inc.*, No. IPR2014–01458, 2016 WL 1085103, 2016 Pat. App. LEXIS 7572 (P.T.A.B. Mar. 17, 2016); *Microsoft Corp. v. Biscotti Inc.*, No. IPR2014–01459, 2016 WL 1084802, 2016 Pat. App. LEXIS 7573 (P.T.A.B. Mar. 17, 2016). Because the Board’s decisions are supported by substantial evidence and do not rely on an erroneous claim construction, we affirm.

I. BACKGROUND

A. The ’182 Patent

The ’182 patent is entitled “Real Time Video Communications System.” The ’182 patent discloses “tools and techniques for providing video calling solutions” and relates to real-time video conferencing where two or more users communicate, over a network, in a conference that includes video and audio of each participant. ’182 patent, Abstract.

The patent explains that there are various video calling technologies on the market, but it states that “there have been no satisfactory video calling options for consumers.” *Id.* at col. 1 ll. 42–46. The ’182 patent notes three different types of video calling systems available at the time of this patent: (1) professional-grade systems that require complex hardware and are expensive and difficult to use; (2) personal computer systems, such as web cams and video chat software like Skype, that have “far from optimal” call quality, require the use of a personal

computer, and use confusing and error-prone software and hardware; and (3) dedicated video phones that are expensive, require multiple phones to communicate with others, and fail to provide adequate call quality because they use small screens and operate over a standard “plain old telephone system.” *Id.* at col. 1 l. 46–col. 2 l. 4. The ’182 patent claims that it provides a system that “solves these and other deficiencies found in current products.” *Id.* at col. 2 ll. 5–6.

The patented video communication system includes components such as video communication devices, the internet, video sources, display devices, and set-top boxes. *Id.* at col. 5 l. 40–col. 6 l. 13. The first video communication device captures a video or audio stream from a video source. *Id.* at col. 5 ll. 49–56. The second video communication device similarly captures a video or audio stream from a second video source. *Id.* The first and second video communication devices can output the video or audio stream they receive from their respective video source to the display devices. *Id.* at col. 5 ll. 56–62.

Each video communication device also is connected to a set-top box. *Id.* at col. 5 ll. 62–65. This allows the video communication device to receive an audiovisual stream from the set-top box and transmit it to the display device. *Id.* at col. 5 l. 65–col. 6 l. 1.

*2 The video communication devices can send their video or audio streams to one another across the internet. *Id.* at col. 5 ll. 42–44; *id.* col. 6 ll. 1–13. For example, the first video communication device can receive a video or audio stream over the internet from the second video communication device. *Id.* The first video communication device then can display the video or audio stream from the second video communication device using its display device. *Id.* The second video communication device similarly can receive a video or audio stream over the internet from the first video communication device. *Id.* The second video communication device then can display the video or audio stream from the first video communication device using its display device. *Id.* This exchange might happen as part of a video call between the two video communication devices.

In some embodiments, the video communication devices can simultaneously display the respective audiovisual streams from the respective set-top boxes so that the display device shows the video or audio stream (from

either video communication device) and the audiovisual stream from the set-top box at the same time. *Id.* at col. 6 ll. 14–18. In this type of situation, the video or audio stream might be sent across the internet to another video communication device, but the audiovisual stream from the set-top box would not be sent over the internet to the other video communication device. This functionality would allow a user to participate in a video call while also watching television at the same time. *Id.* at col. 6 ll. 18–20.

Figure 4 of the patent shows that the video communication device includes an input video interface and an input audio interface through which the video communication device can receive video and audio from a set-top box. *Id.* at col. 10 ll. 19–22, 48–52. The video communication device also includes an output video interface and an output audio interface through which the video communication device can transmit video and audio to a display device. *Id.* at col. 10 ll. 19–22, 59–67. The video communication device has an audio capture device and a video capture device through which it can receive audio and video; for example, these features might include a microphone and a camera to capture speech and footage of a video call participant. *Id.* at col. 11 ll. 3–12. The video communication device also includes a network interface that allows a connection to a network, which can be used to communicate with a server or another video communication device. *Id.* at col. 11 ll. 25–31.

The video communication device also includes a processor, codecs, and a storage medium. *Id.* at col. 9 ll. 64–66, col. 10 ll. 11–18. The processor generally controls the operation of the video communication device. *Id.* at col. 9 ll. 64–66. The codecs provide the video communication device with encoding and decoding functionality. *Id.* at col. 10 ll. 11–14. The storage medium is “encoded with instructions executable by the processor, can provide working memory for execution of those instructions, [and] can be used to cache and/or buffer media streams, and/or the like.” *Id.* at col. 10 ll. 14–18.

The '182 patent has four independent claims, but only two are relevant to these appeals—claims 6 and 69. Independent claim 6 reads:

A video communication system, comprising:
 a first video communication device, comprising:

[A] a video input interface to receive video input from a set-top box;

[B] an audio input interface to receive audio input from the set-top box;

[C] a video output interface to provide video output to a video display device;

[D] an audio output interface to provide audio output to an audio receiver;

[E] a video capture device to capture video;

[F] an audio capture device to capture audio;

[G] a network interface;

[H] at least one processor; and

[I] a storage medium in communication with the at least one processor, the storage medium having encoded thereon a set of instructions executable by the at least one processor to control operation of the first video communication device, the set of instructions comprising:

*3 [i] instructions for controlling the video capture device to capture a captured video stream;

[ii] instructions for controlling the audio capture device to capture a captured audio stream;

[iii] instructions for encoding the captured video stream and the captured audio stream to produce a series of data packets; and

[iv] instructions for transmitting the series of data packets on the network interface for reception by a second video communication device.

Id. at col. 32 l. 62–col. 33 l. 25. Claim 6 and certain claims depending from claim 6 were at issue in the first two IPRs.

Independent claim 69 reads:

A method of providing video calling using a first video communication device comprising an audio capture device, a video capture device, a network interface, an audiovisual input interface, and an audiovisual output interface, the method comprising:

[A] receiving, on the audiovisual input interface, a set-top box audiovisual stream from a set-top box, the set-top box audiovisual stream comprising a set-top box video stream and a set-top box audio stream;

[B] receiving, on the network interface, a remote audiovisual stream via a network connection with a second video communication device, the remote audiovisual stream comprising a remote audio stream and a remote video stream;

[C] transmitting, on the audiovisual output interface, a consolidated output video stream comprising at least a portion of the remote video stream and a consolidated output audio stream comprising at least the remote audio stream;

[D] capturing a captured video stream with the video capture device;

[E] capturing a captured audio stream with the audio capture device;

[F] encoding the captured video stream and the captured audio stream to produce a series of data packets; and

[G] transmitting the series of data packets on the network interface for reception by the second video communication device.

Id. at col. 37 l. 63–col. 38 l. 23. Claim 69 and certain claims depending from claim 69 were at issue in the third IPR.

B. The Kenoyer Reference

[U.S. Patent No. 7,907,164 \(“Kenoyer”\)](#), entitled “Integrated Videoconferencing System,” was filed on April 17, 2006, and issued on March 15, 2011. Its invention “relates generally to conferencing and, more specifically, to videoconferencing.” Kenoyer, col. 1 ll. 22–23. The reference explains that videoconferencing allows “two or more participants at remote locations to communicate using both video and audio.” *Id.* at col. 1 ll. 25–27.

Kenoyer discloses a “multi-component videoconferencing system” that “may include a camera, microphones, speakers, and a codec possibly used in conjunction with a computer system.” *Id.* at col. 1 ll. 43–47. Kenoyer

explains that it is “susceptible to various modifications and alternative forms.” *Id.* at col. 3 ll. 17–18. The system’s video and audio conferencing capabilities “may be implemented over various types of networked devices.” *Id.* at col. 4 ll. 15–16. An embodiment of the invention implemented over a network is provided in Figure 1:

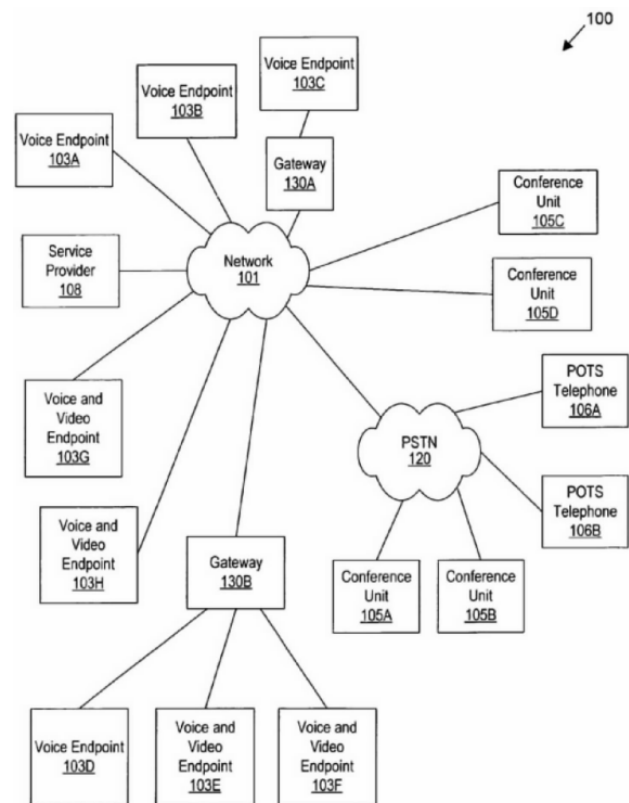

FIG. 1

Id. at Fig. 1. The video conferencing system includes a network (101) with endpoints (103A–103H), gateways (130A and 130B), a service provider (108), a public switched telephone network (120), conference units (105A–105D), and telephones from a “plain old telephone system” (106A and 106B). *Id.* at col. 3 l. 64–col. 4 l. 4.

*4 The endpoints (103A–103H) can be audio or videoconferencing systems. *Id.* at col. 3 ll. 66–67. Kenoyer explains that certain endpoints (103D–103H) may include audio and video communication capabilities to create video conferencing capability. *Id.* at col. 4 ll. 35–46. These endpoints also can include or be coupled to various audio devices, such as microphones, audio input devices, speakers, and audio output devices. *Id.* at col. 4 ll. 35–39. And these endpoints can include or be coupled to various video devices, such as monitors, projectors, televisions, video output devices, or video input devices. *Id.* at col. 4 ll. 44–46. The endpoints “may comprise various ports for

coupling to one or more devices (e.g., audio devices, video devices, etc.) and/or to one or more networks.” *Id.* at col. 4 ll. 47–49.

Figure 3 of Kenoyer shows a participant location with a multi-component video conferencing system:

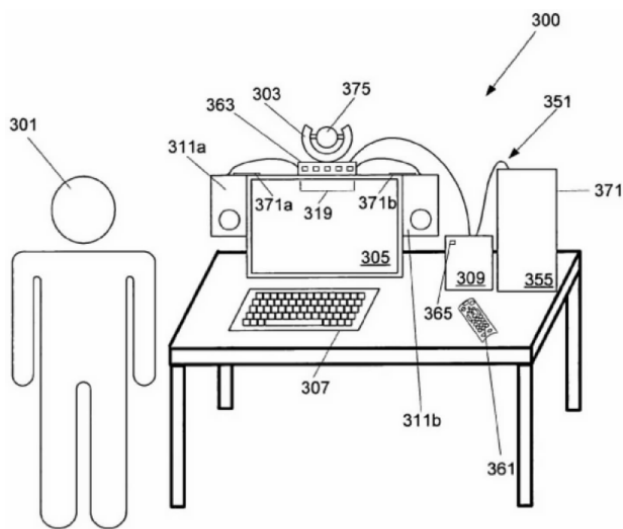

FIG. 3

Id. at Fig. 3. Kenoyer explains that a participant can use the multi-component video conferencing system (300) to communicate with other participants in a video conference. *Id.* at col. 6 ll. 1–4. The multi-component video conferencing system (300) includes the following components: a camera (303) with a camera base (363) and lens portion (375); a display (305); a keyboard (307); a codec (309); speakers (311a and 311b) with speaker attachments (371a and 371b); microphones (319); a network connection (351); a computer system (355); a remote control (361); and a remote sensor (365). *Id.* at col. 6 l. 4–col. 8 l. 49. A participant can use the camera to capture video, the microphone to capture audio while using the display to provide video from a local or remote conference participant, and the speakers to produce audio from remote conference participants. *Id.* at col. 6 ll. 4–9. Figure 5 of Kenoyer shows a side view of an embodiment of a codec:

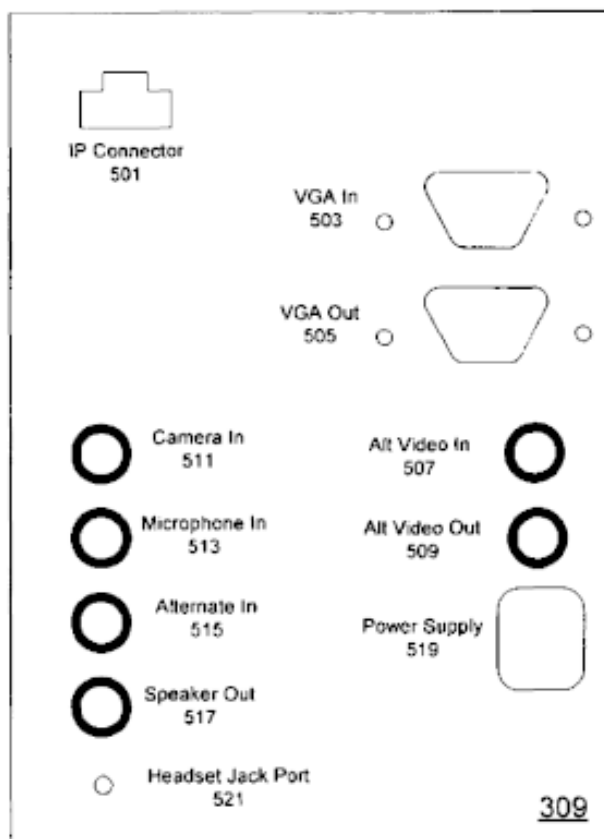

FIG. 5

Id. at Fig. 5. Kenoyer explains that the codec can include multiple ports on one or more sides of the codec. *Id.* at col. 8 ll. 57–60. As shown in Figure 5, the codec can have ports for a camera, a microphone, a speaker, video input, video output, and an IP connector. *Id.* at col. 8 l. 66–col. 9 l. 17. Aside from Figure 5, Kenoyer includes other teachings regarding the codec. It states that “a codec (which may mean short [sic] for ‘compressor/decompressor’) may comprise any system and/or method for encoding and/or decoding (e.g., compressing and decompressing) data (e.g., audio and/or video data).” *Id.* at col. 4 l. 67–col. 5 l. 4. In different embodiments, the codec “may be implemented in software, hardware, or a combination of both.” *Id.* at col. 5 ll. 9–10. The codec can be incorporated into other components, such as a camera base or a set-top box. *Id.* at col. 1 ll. 56–63. The codec also can be separated out to “an independent housing that is coupled to the set-top box,” which allows the codec to “act as a pass-through for the regular programming/games when

a conference is not being held” or to “display at least a portion of the programming/games along with video for the videoconference.” *Id.* at col. 10 ll. 25–30.

Figure 22 of Kenoyer shows a method of video conferencing through the multi-component video conferencing system:

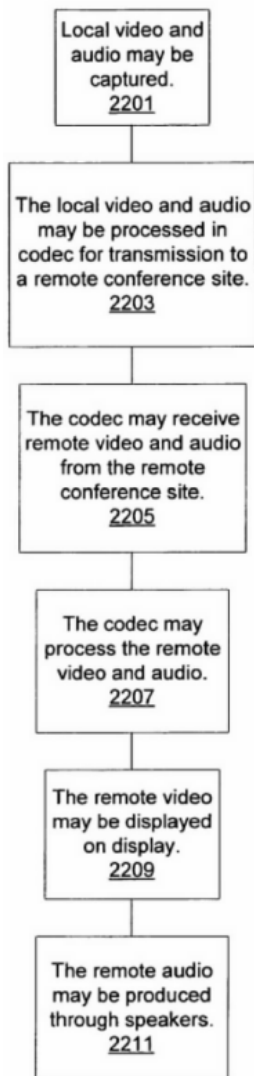

FIG. 22

Id. at Fig. 22. Kenoyer's description of Figure 22 notes that “in various embodiments of the methods described below, one or more of the elements described may be performed concurrently, in a different order than shown, or may be omitted entirely. Other additional elements may also be performed as desired.” *Id.* at col. 15 ll. 2–7. Kenoyer then writes out the steps shown in Figure 22. *Id.* at col. 15 ll. 8–20.

After writing out the steps shown in Figure 22, Kenoyer states, “[e]mbodiments of a subset or all (and portions

or all) of the above may be implemented by program instructions stored in a memory medium or carrier medium and executed by a processor.” *Id.* at col. 15 ll. 21–24. Kenoyer begins the next paragraph by stating, “[i]n some embodiments, a computer system at a respective participant location may include a memory medium(s) on which one or more computer programs or software components according to one embodiment of the present invention may be stored.” *Id.* at col. 15 ll. 46–50. The next paragraph states, “[f]urther modifications and alternative embodiments of various aspects of the invention may be apparent to those skilled in the art in view of this description.” *Id.* at col. 15 ll. 55–57. It also states that “[e]lements and materials may be substituted for those illustrated and described herein, parts and processes may be reversed, and certain features of the invention may be utilized independently, all as would be apparent to one skilled in the art after having the benefit of this description of the invention.” *Id.* at col. 15 ll. 62–67.

C. Procedural History

*5 In November 2013, Biscotti, Inc. (“Biscotti”) sued Microsoft in the U.S. District Court for the Eastern District of Texas alleging that Microsoft infringed the '182 patent. Microsoft filed three separate IPRs in September 2014 challenging certain claims of the '182 patent on anticipation and obviousness grounds. As relevant here, the Board instituted review of claims 6 and 69 on anticipation grounds, and of claims that depend from claims 6 and 69 on anticipation and obviousness grounds. The first two IPRs, IPR2014–01457 (“57 IPR”) and IPR2014–01458 (“58 IPR”), focused on independent claim 6 and claims that depend from claim 6. The third IPR, IPR2014–01459 (“59 IPR”), focused on independent claim 69 and claims that depend from claim 69. In each IPR, the Board ultimately found that Microsoft failed to prove by a preponderance of the evidence that Kenoyer anticipated the challenged claims or rendered those claims obvious.

1. The 57 IPR

The Board began its analysis in the 57 IPR by discussing Microsoft's assertion that Kenoyer anticipated claim 6 of the '182 patent. 57 IPR, at *— – —, 2016 Pat. App. LEXIS 7571, at *14–19. In support of its argument,

Microsoft asserted that the “storage medium” limitation of claim 6 was disclosed by the following language from Kenoyer's specification: “[e]mbodiments of a subset or all (and portions or all) of the above may be implemented by program instructions stored in a memory medium or carrier medium and executed by a processor.” *Id.* at *6, 2016 Pat. App. LEXIS 7571 at *18–*19 (citing Kenoyer, col. 15 ll. 21–24). Microsoft's expert, Dr. Houh, testified that this language “describes using computer programs to implement the codec and other functionality described in that patent.” *Id.* at *6, 2016 Pat. App. LEXIS 7571 at *19 (citing J.A. 2288 ¶ 100). Regarding the specific “instructions” sub-limitations, Microsoft and its expert argued that the specification, at various places, disclosed the functions described by the instructions. *Id.*

Biscotti contended that the language cited by Microsoft referred only to the description of Figure 22, which immediately preceded the language on which Microsoft relied, rather than all of the disclosures made throughout the Kenoyer specification. *See id.* at *—— – ——, 2016 Pat. App. LEXIS 7571, at *19–20. Biscotti and its expert, Dr. Bovik, argued that the language could not apply to all prior disclosures in the specification because the specification discussed certain components, such as cooling fans and handles to carry equipment, that could not have been implemented in a storage medium. *Id.* at *——, 2016 Pat. App. LEXIS 7571, at *21. Biscotti argued that the more natural interpretation of the language was that it applied only to the discussion of Figure 22. *Id.* at *——, 2016 Pat. App. LEXIS 7571, at *20. Biscotti asserted that the language's application was further supported by another portion of the description of Figure 22, which referred to the various “embodiments of the methods *described below*.” *Id.* (quoting Kenoyer, col. 15 ll. 3–4) (emphasis added). This language applied to the textual description of the steps laid out in Figure 22, and Biscotti argued that the similar language relied upon by Microsoft—which stated “[e]mbodiments of a subset or all (and portions or all) of the above,” Kenoyer, col. 15 ll. 21–22 (emphasis added)—naturally applied to the description of Figure 22 as well. *57 IPR*, at *——, 2016 Pat. App. LEXIS 7571, at *20.

The Board found that Microsoft failed to prove that Kenoyer's disclosure anticipated the “storage medium” and “instructions” limitations of claim 6 of the '182 patent. *Id.* at *—— – ——, 2016 Pat. App. LEXIS 7571, at *24–25. The Board noted that Microsoft's argument regarding

the “storage medium” and “instructions” limitations relied on an interpretation of the disputed language of column 15 “referring to and tying together a number of disclosures in various portions throughout Kenoyer regarding functions that may be performed in various embodiments.” *Id.* at *8, 2016 Pat. App. LEXIS 7571, at *24 (citing J.A. 176–79). The Board found that “Kenoyer's program-instructions sentence does not make sense as a disclosure blanketing all of the preceding 34 pages,” and that the sentence “does not refer back specifically to the various other disclosures cited by [Microsoft].” *Id.* at *9, 2016 Pat. App. LEXIS 7571, at *26. Instead, the Board found that Biscotti's argument and evidence regarding the meaning of the sentence was “at least as persuasive as [Microsoft's] argument and evidence” such that Microsoft had failed to meet its burden of proof. *Id.* at *9, 2016 Pat. App. LEXIS 7571, at *27.

*6 The Board further noted that it “makes sense that a videoconferencing method would lend itself to implementation with program instructions,” and it “makes sense that the program-instructions sentence would refer specifically to the videoconferencing method disclosed” in the discussion of Figure 22. *Id.* at *9, 2016 Pat. App. LEXIS 7571, at *27. The Board therefore “agree[d] with [Biscotti]” that Kenoyer's reference to “embodiments of the methods described below” and “[e]mbodiments of a subset or all (and portions or all) of the above” both refer to the description of Figure 22. *Id.* at *—— – ——, 2016 Pat. App. LEXIS 7571, at *27–28. The Board accordingly found that Microsoft had not “demonstrated by a preponderance of the evidence that Kenoyer's program-instructions sentence and various other cited portions disclose the claimed ‘storage medium’ with its four specific ‘instructions for,’ or that a person of ordinary skill in the art would ‘at once envisage’ a storage medium with the specific instructions claimed.” *Id.* at *10, 2016 Pat. App. LEXIS 7571, at *28–29.

The Board explained that Kenoyer's alleged disclosures of a storage medium with instructions in accordance with the limitations of claim 6 “are unrelated to each other in [the] disclosure.” *Id.* at *10, 2016 Pat. App. LEXIS 7571, at *29. The Board compared this to a disclosure that amounted to “multiple, distinct teachings that the artisan might somehow combine to achieve the claimed invention,” which is insufficient to anticipate. *Id.* at *—— – ——, 2016 Pat. App. LEXIS 7571, at *29–30 (citing *Net MoneyIN, Inc. v. VeriSign, Inc.*, 545 F.3d 1359, 1369 (Fed. Cir. 2008)

(internal quotation marks omitted)). It also found that Microsoft failed to provide “persuasive evidence that the disclosure would be understood by one of ordinary skill in the art to mean that the storage medium with program instructions and the functions performed in the various embodiments are used together in Kenoyer.” *Id.* at *10, 2016 Pat. App. LEXIS 7571, at *30. The Board therefore found that Kenoyer did not anticipate claim 6 of the '182 patent. *Id.*

Because claims 24–26, 28, 29, 31, 37, and 41 all depended on claim 6, the Board found that Microsoft failed to prove by a preponderance of the evidence that Kenoyer anticipated the claims. *Id.* at *———, 2016 Pat. App. LEXIS 7571, at *32–33.

Turning to the obviousness arguments for claims 36 and 37, the Board found that Microsoft failed to prove obviousness over Kenoyer and other references. Microsoft asserted that Kenoyer discloses the “storage medium” and “instructions” limitations, but the Board concluded that Microsoft failed to prove that Kenoyer taught the limitations, as discussed in the anticipation analysis. *Id.* at *———, 2016 Pat. App. LEXIS 7571, at *33–34. Microsoft did not separately address whether Kenoyer rendered the limitations of claim 6 obvious based on the teachings located in different parts of the specification, so Microsoft failed to prove obviousness for claims 36 and 37. *Id.* at *———, 2016 Pat. App. LEXIS 7571, at *34.

One of the judges on the Board dissented from the Board's conclusions. The dissent argued that the majority erred when applying the law regarding § 102 to the teachings of Kenoyer because it failed to “take into account not only specific teachings of the reference but also the inferences which one skilled in the art would reasonably be expected to draw therefrom.” *Id.* at *13, 2016 Pat. App. LEXIS 7571, at *39 (Cherry, A.P.J., dissenting) (citing *In re Preda*, 401 F.2d 825, 826 (CCPA 1968)). “Even assuming that Kenoyer did not disclose expressly the use of program instructions, I am persuaded by the evidence presented that a person of ordinary skill would recognize its description as disclosing the use of program instructions (software) to enable the performance of these functions.” *Id.* at *13, 2016 Pat. App. LEXIS 7571, at *40 (citing *J.A.* 8422–23 ¶ 57; *In re Alappat*, 33 F.3d 1526, 1583 (Fed. Cir. 1994) (en banc) (Rader, J., concurring)). The dissent also asserted that the use of “embodiments” throughout Kenoyer's specification suggested that the

disputed language was not as limited as Biscotti had argued. *Id.* at *———, 2016 Pat. App. LEXIS 7571, at *41–42.

The majority responded to the dissent by stating that Microsoft did not make the arguments relied upon by the dissent and that, even were they to agree with the dissent's reasoning, Microsoft had not met its burden of proving anticipation. *Id.* at *———, 2016 Pat. App. LEXIS 7571, at *31–32.

2. The 58 IPR

*7 Because the Board primarily considered claim 6 in the 58 IPR, as it did in the 57 IPR, the final written decision in the 58 IPR is very similar to the decision in the 57 IPR. Based on the same reasoning and underlying findings, the Board found that Kenoyer did not anticipate claim 6 of the '182 patent. *58 IPR*, at *———, 2016 Pat. App. LEXIS 7572, at *25–33. The Board similarly found that Microsoft failed to prove Kenoyer anticipated the dependent claims. *Id.* at *———, 2016 Pat. App. LEXIS 7572, at *33. The same administrative judge dissented from the Board's decision in the 58 IPR, and the dissent, like the majority, is similar to the dissent issued in the 57 IPR.

In addressing obviousness, the Board again performed a similar analysis to that performed in the final written decision for the 57 IPR. The Board found that Microsoft failed to prove that Kenoyer taught the “storage medium” and “instructions” limitations of claim 6 and failed to provide additional argument as to how Kenoyer might render the limitation obvious when the anticipation challenge failed, so Microsoft failed to meet its burden of providing obviousness for these dependent claims. *Id.* at *———, 2016 Pat. App. LEXIS 7572, at *33–35.

3. The 59 IPR

The Board began its analysis in the 59 IPR by discussing Microsoft's assertion that Kenoyer anticipated claim 69 of the '182 patent. Microsoft argued that Kenoyer disclosed receiving audio and video from the set-top box using an audiovisual input interface. *59 IPR*, at *———, 2016 Pat. App. LEXIS 7573, at *17–18. Microsoft provided two statements to demonstrate disclosure: (1) “[t]he codec's

audio and video processing may be incorporated in the set-top box and/or may be distributed (e.g., to other devices through a cable coupling the devices to the set-top box”); and (2) “[t]he codec may also be in an independent housing that is coupled to the set-top box 705. The codec may act as a pass-through for the regular programming/games when a conference is not being held” (the “pass-through clause”). *Id.* The Board found, however, that Kenoyer does not expressly disclose an interface in either statement. *Id.* at *—, 2016 Pat. App. LEXIS 7573, at *18. The Board further found that Microsoft did not explain any basis for finding that a person of ordinary skill in the art (“POSA”) would understand the two statements as disclosing an “interface.” *Id.* at *— – —, 2016 Pat. App. LEXIS 7573, at *18–19. The Board noted that the statements could *inherently* disclose the claimed interface, but Microsoft failed to provide, as inherency requires, any evidence why a POSA would understand the statements as necessarily disclosing the claimed interface. *Id.* at *—, 2016 Pat. App. LEXIS 7573, at *19.

Rather than rely on inherency, Microsoft asserted that Kenoyer's pass-through clause and the interface in Figure 5 provided adequate disclosure. *Id.* at *— – —, 2016 Pat. App. LEXIS 7573, at *19–20. Microsoft argued that the pass-through clause disclosed receiving audio and video, and Figure 5 disclosed an audiovisual input interface on which the audio and video are actually received. *Id.* Dr. Houh provided that a POSA would “consider the import of Kenoyer's disclosure of connecting the set-top box to the codec together with Kenoyer's disclosure a codec [sic] with audio and video input interfaces.” *Id.* at *7, 2016 Pat. App. LEXIS 7573, at *21 (emphasis omitted). Dr. Houh further provided that “ ‘such persons would have interpreted Kenoyer's disclosure of a codec separate from and coupled to a set-top box as meaning that the set-top box would be coupled to the codec using the interfaces that Kenoyer discloses are included in the codec’ because ‘[s]uch persons would understand that each of the codec's video inputs described by Kenoyer was capable of receiving video input from a set-top box.’ ” *Id.* (alteration in original).

Biscotti countered that the codec on which Microsoft relied did not have an input interface to receive audio or video from a set-top box; instead, it received video input from a computer. *Id.* at *— – —, 2016 Pat. App. LEXIS 7573, at *21–22. Biscotti explained that Figure 5

shows a codec (309) connected to a computer, not a set-top box. *Id.* at *—, 2016 Pat. App. LEXIS 7573, at *22.

*8 Biscotti and Dr. Bovik also asserted that Kenoyer's Microphone In (513), Alternate In (515), VGA In (503), or Alt Video In (507) do not indicate that they would be used to connect to a set-top box. *Id.* at *— – —, 2016 Pat. App. LEXIS 7573, at *22–23. Dr. Bovik testified that only Kenoyer's Microphone In (513) and Alternate In (515) could potentially be an input interface to receive audio from the set-top box, but neither was described in Kenoyer as being such an interface. *Id.* Regarding Microphone In (513), Dr. Bovik testified that “a microphone-in connection is not the type of connection one of ordinary skill would consider to be an input interface to receive audio input from the set-top box; indeed, by its very name, it would likely receive input audio from a microphone.” *Id.* at *7, 2016 Pat. App. LEXIS 7573, at *23. Lastly, Dr. Bovik testified that Kenoyer disclosed Alternate In (515) receiving signals from a camera and a microphone array, not audio from a set-top box. *Id.*

The Board found that Microsoft had not shown by a preponderance of the evidence that Kenoyer disclosed all aspects of the claim limitation, primarily because Microsoft had combined separate embodiments within Kenoyer to account for the limitations of the claim, which the Board considered an improper basis for anticipation. *Id.* at *—, 2016 Pat. App. LEXIS 7573, at *26. The Board noted that Kenoyer discloses two distinct embodiments: Figure 5 shows an embodiment of a codec, and Figures 7a and 7b show an embodiment of a multi-component video conferencing system with codec functionality incorporated in a set-top box. *Id.* at *— – —, 2016 Pat. App. LEXIS 7573, at *26–27. The Board also explained that the pass-through discussion was provided in connection with the embodiment of Figures 7a and 7b, not the embodiment of Figure 5. *Id.* at *—, 2016 Pat. App. LEXIS 7573, at *27. Consequently, the Board found Dr. Houh's testimony that a POSA would treat all the different teachings together contradicted Kenoyer's disclosure that these were separate embodiments and was entitled to little weight. *Id.* (citing *Network Commerce, Inc. v. Microsoft Corp.*, 422 F.3d 1353, 1361 (Fed. Cir. 2005) (“[E]xpert testimony at odds with the intrinsic evidence must be disregarded.”)).

Additionally, the Board found Microsoft's argument unpersuasive regarding Microphone In (513), Alternate In (515), VGA In (503), or Alt Video In (507). *Id.* at *———, 2016 Pat. App. LEXIS 7573, at *28–29. The Board noted that Kenoyer's description of the embodiment illustrated in Figures 7a and 7b of a “multi-component videoconferencing system” (“MCVCS”) with codec functionality incorporated in a set top box, including the pass-through passage, did not contain any specific reference to Microphone In (513), Alternate In (515), VGA In (503), or Alt Video In (507). *Id.* Thus, the Board found unpersuasive Dr. Houh's testimony that a POSA would understand such inputs to receive the regular programming/games because those inputs are *capable* of receiving video input from a set-top box. *Id.* The Board found it even less persuasive because Biscotti's arguments and evidence cast “substantial doubt” regarding whether a POSA would consider the inputs appropriate for receiving video or audio from a set-top box, and Dr. Houh cited no evidence to support his assertion. *Id.*

The Board also found that, even if it were to accept that a POSA would understand that Microphone In (513), Alternate In (515), VGA In (503), or Alt Video In (507) are capable of receiving regular programming from a set-top box, “the mere possibility of combining the disclosed embodiments in the specific manner suggested by Petitioner and Dr. Houh does not persuade us that a person of ordinary skill in the art would have understood Kenoyer as disclosing combining the disclosed embodiments in the specific manner suggested by Petitioner and Dr. Houh.” *Id.* at *10, 2016 Pat. App. LEXIS 7573, at *30. The Board found it particularly unpersuasive that Kenoyer did not link the separate embodiments. *Id.* at *———, 2016 Pat. App. LEXIS 7573, at *30–31 (citing *Lindemann Maschinenfabrik GMBH v. Am. Hoist & Derrick Co.*, 730 F.2d 1452, 1458, 1459 (Fed. Cir. 1984), for the proposition that requiring the prior art elements themselves to be “arranged as in the claim” means that claims cannot be “treated ... as mere catalogs of separate parts, in disregard of the part-to-part relationships set forth in the claims and that give the claims their meaning”). The Board thus concluded that Microsoft had failed to demonstrate by a preponderance of the evidence that Kenoyer anticipated claim 69. *Id.* at *———, 2016 Pat. App. LEXIS 7573, at *31.

*9 The Board noted that, because each of claims 70, 71, and 74 depends from independent claim 69, claims

70, 71, and 74 included claim 69's “receiving” limitation. *Id.* at *———, 2016 Pat. App. LEXIS 7573, at *33. The Board found that, when addressing claims 70, 71, and 74, Microsoft did not overcome the shortcomings in its assertion that Kenoyer disclosed the “receiving” limitation of claim 69. *Id.* The Board therefore found that Microsoft had not demonstrated by a preponderance of the evidence that Kenoyer anticipated claims 70, 71, and 74. *Id.* There was no dissent from the Board's findings in this IPR.

II. DISCUSSION

A. Standard of Review

1. Anticipation

Microsoft's briefing challenges our standard of review as to anticipation. According to Microsoft, the Board's “conclusion” on anticipation was not a finding of fact but instead a conclusion based on “construing a written instrument,” which is a legal task afforded no deference. Appellant's Br. 42. Microsoft also asserts that the prior art reference is a patent, and the interpretation of a patent's intrinsic evidence, such as the interpretation of the specification here, is reviewed without deference. *Id.* (citing *Teva Pharm. USA, Inc. v. Sandoz, Inc.*, — U.S. —, 135 S.Ct. 831, 841, —L.Ed.2d — (2015)). Microsoft then claims that the Board did not make “any specific findings of its own” and instead “agreed with Biscotti that it made more sense to read Kenoyer's program instructions sentence restrictively, to apply only to the particular method described in Figure 22.” *Id.* at 43.

Microsoft confirmed this view in its reply brief by maintaining that the Board's anticipation decisions “turned on how to read the Kenoyer patent” and involved “no credibility findings.” Appellant's Reply Br. 9. Microsoft claims that the perspective of a POSA in the context of this case is the same perspective at issue in claim construction, and that which would literally infringe if later, anticipates if earlier. *Id.* at 10 (citing *Upsher-Smith Labs., Inc. v. Pamlab, L.L.C.*, 412 F.3d 1319, 1322 (Fed. Cir. 2005)). Microsoft contends that the inquiries therefore are mirror images because they both depend on how a POSA would read Kenoyer's intrinsic evidence. *Id.* Based on this reasoning, Microsoft claims that there is “no

persuasive reason that the deference afforded in the two contexts should be polar opposites.” *Id.*

Despite these assertions, Microsoft stated at oral argument that it was not challenging our standard of review on anticipation. Instead, Microsoft acknowledged that anticipation is a factual question that this court reviews for substantial evidence. *See* Oral Arg. at 2:49–4:05, <http://oralarguments.cafc.uscourts.gov/default.aspx?fl=2016-2080.mp3> (“We completely recognize that anticipation is a question of fact [subject to] substantial evidence review.... If we gave the impression that we were saying generally you shouldn't treat anticipation as a question of fact, ... that certainly wasn't what we were trying to convey.”).

[1] Although Microsoft retreated from challenging our standard of review, we reiterate that anticipation is a question of fact subject to substantial evidence review. Indeed, case law from the Supreme Court and this court has stated for decades that anticipation is a factual question. *See, e.g., Busch v. Jones*, 184 U.S. 598, 604, 22 S.Ct. 511, 46 L.Ed. 707 (1902) (“Anticipation is a question of fact[.]”); *Reckendorfer v. Faber*, 92 U.S. 347, 352, 23 L.Ed. 719 (1876) (“The defence of want of novelty is set up every day in the courts, and is determined by the court or the jury as a question of fact upon the evidence adduced[.]”); *Kennametal, Inc. v. Ingersoll Cutting Tool Co.*, 780 F.3d 1376, 1381 (Fed. Cir. 2015) (“Anticipation under 35 U.S.C. § 102 is a question of fact[.] ... We review the Board's factual findings for substantial evidence....”); *In re Gleave*, 560 F.3d 1331, 1334–35 (Fed. Cir. 2009) (“After all, anticipation is a question of fact, including whether an element is inherent in the prior art.”).

*10 We therefore consider whether the Board's findings on anticipation in this case are supported by substantial evidence.

2. Claim Construction

[2] [3] [4] The Court reviews *de novo* the “ultimate construction of [a] claim,” as well as any claim construction relying only on intrinsic evidence. *Teva Pharm. USA, Inc. v. Sandoz, Inc.*, — U.S. —, 135 S.Ct. 831, 841, — L.Ed.2d — (2015). Subsidiary factual findings based on extrinsic evidence, if any, are reviewed for substantial evidence. *PPC Broadband, Inc. v. Corning*

Optical Commc'ns RF, LLC, 815 F.3d 747, 751 (Fed. Cir. 2016). Unexpired claims subject to IPR are to be given their “broadest reasonable construction.” *Cuozzo Speed Techs., LLC v. Lee*, — U.S. —, 136 S.Ct. 2131, 2136, 195 L.Ed.2d 423 (2016).

B. The Board's Anticipation Findings

1. The Legal Standard Applied by the Board

[5] [6] As relevant here, a patent is invalid as anticipated if “the invention was described in” a patent or published application “before the invention by” the patentee. 35 U.S.C. § 102(e). In order to anticipate the claimed invention, a prior art reference must “disclose all elements of the claim within the four corners of the document,” and it must “disclose those elements ‘arranged as in the claim.’ ” *Net MoneyIN, Inc. v. VeriSign, Inc.*, 545 F.3d 1359, 1369 (Fed. Cir. 2008) (quoting *Connell v. Sears, Roebuck & Co.*, 722 F.2d 1542, 1548 (Fed. Cir. 1983)). “However, a reference can anticipate a claim even if it ‘d[oes] not expressly spell out’ all the limitations arranged or combined as in the claim, if a person of skill in the art, reading the reference, would ‘at once envisage’ the claimed arrangement or combination.” *Kennametal*, 780 F.3d at 1381 (alteration in original) (quoting *In re Petering*, 301 F.2d 676, 681 (CCPA 1962)); *see also Blue Calypso, LLC v. Groupon, Inc.*, 815 F.3d 1331, 1344 (Fed. Cir. 2016) (“[A] reference may still anticipate if that reference teaches that the disclosed components or functionalities may be combined and one of skill in the art would be able to implement the combination.” (citing *Kennametal*, 780 F.3d at 1383)).

Microsoft argues that the Board applied an “unduly narrow anticipation standard” in its final written decision. Appellant's Br. 32. Microsoft asserts that a prior art reference must be viewed in its “totality” for what it describes, *id.* at 33 (citing *In re Donohue*, 632 F.2d 123, 126 (CCPA 1980); *In re Schaumann*, 572 F.2d 312, 317 (CCPA 1978)), and does not have to disclose anything more than is described in the challenged invention, *id.* (citing *Iovate Health Scis., Inc. v. Bio-Engineered Supplements & Nutrition, Inc.*, 586 F.3d 1376, 1382 (Fed. Cir. 2009)). Microsoft particularly relies on our decisions in *Kennametal* and *Blue Calypso* to argue that a prior art reference does not need to disclose all the limitations arranged or combined as in the claim in order

to anticipate if a POSA “would at once envisage” the claimed arrangement. *Id.* at 33–34; see *Kennametal*, 780 F.3d at 1381; *Blue Calypso*, 815 F.3d at 1344.

[7] [8] Contrary to Microsoft's contentions, however, Biscotti correctly argues that the Board set forth the proper anticipation standard in its final written decisions. The Board noted that a prior art reference must provide every element of the claimed invention arranged as in the claim in order to anticipate. *E.g.*, *57 IPR*, *—— ———, 2016 Pat. App. LEXIS 7571, at *23–24 (citing *Karsten Mfg. Corp. v. Cleveland Golf Co.*, 242 F.3d 1376, 1383 (Fed. Cir. 2001); *In re Bond*, 910 F.2d 831, 832 (Fed. Cir. 1990)). But the Board also stated that a claim does not need to “expressly spell out” all limitations combined as in the claim if a POSA would “at once envisage” the arrangement or combination. *Id.* at *8, 2016 Pat. App. LEXIS 7571, at *24 (quoting *Kennametal*, 780 F.3d at 1381 (internal quotation marks omitted)). The Board then correctly stated that anticipation is not proven by “multiple, distinct teachings that the artisan might somehow combine to achieve the claimed invention.” *Id.* at *10, 2016 Pat. App. LEXIS 7571, at *29–30 (quoting *Net MoneyIN*, 545 F.3d at 1371 (internal quotation marks omitted)).

*11 Because the Board correctly articulated the anticipation standard, Microsoft appears to challenge only whether the Board applied the standard correctly or, instead, set forth additional requirements not covered by a proper interpretation of the anticipation standard. In its reply brief, Microsoft claims that the Board misapplied the anticipation standard by requiring that Kenoyer's disclosure match the '182 patent's limitations exactly. See Appellant's Reply Br. 5–6 (citing *57 IPR*, at *9, 2016 Pat. App. LEXIS 7571, at *26 (“[W]e find that the program-instructions sentence does not refer back specifically to the various other disclosures cited by Petitioner.”); *id.* at *10, 2016 Pat. App. LEXIS 7571, at *28 (“[Microsoft] has not demonstrated by a preponderance of the evidence that the program-instructions sentence relates to the entirety of Kenoyer's disclosure so as to tie together the functions that may be performed throughout Kenoyer in order to anticipate a claim directed to instructions encoded on a storage medium.”); *id.* at *10, 2016 Pat. App. LEXIS 7571, at *28–29 (“We find that [Microsoft] has not demonstrated by a preponderance of the evidence that ... a person of ordinary skill in the art would ‘at once envisage’ a storage medium with the specific instructions

claimed.”); *59 IPR*, at *8, 2016 Pat. App. LEXIS 7573, at *26 (“[Microsoft] has not shown by a preponderance of the evidence that Kenoyer discloses all aspects of the claim limitation ... identically, in the same relationship as in the claim.”)).

[9] Although the Board may have used wording such as “identically” more liberally than it should have because an anticipation analysis indisputably allows for some flexibility, the Board's analysis did not suffer from a misapplication of the anticipation standard. For example, when considering claim 6, the Board analyzed and made factual findings regarding the teachings of Kenoyer, the application of the program-instructions sentence to other embodiments outside of Figure 22, and whether a POSA would “at once envisage” a storage medium with the specific instructions claimed so as to anticipate the '182 patent. See *57 IPR*, at *—— ———, 2016 Pat. App. LEXIS 7571, at *26–30. The Board therefore did not require word-for-word similarity or perfection, as Microsoft claims; to the contrary, the Board explicitly considered whether a POSA would “at once envisage” the combination of the claimed invention given the disconnected teachings in Kenoyer. The Board therefore did not err in its application of the legal standard for anticipation.

The above analysis is not to say, however, that the Board's anticipation analysis itself was correct; we consider below Microsoft's arguments on that score. We find initially, however, that the Board did apply the correct legal standard to its anticipation analysis.

2. Claim 6

[10] In addressing claim 6, the primary dispute on appeal is whether Kenoyer discloses a storage medium with four types of program instructions. This dispute hinges on the meaning of a sentence found near the end of the specification in Kenoyer. That sentence reads: “[e]mbodiments of a subset or all (and portions or all) of the above may be implemented by program instructions stored in a memory medium or carrier medium and executed by a processor.” Kenoyer, col. 15 ll. 21–24. The parties dispute whether this sentence refers only to Figure 22, which was described in the lines immediately preceding this sentence, or instead to all previous figures and embodiments of the patent.

According to Microsoft, the sentence “means what it says: some or all of what is disclosed above in the specification, including ‘a subset or all (and portions or all)’ of the ‘embodiments’ (plural), may be implemented through program instructions (i.e., software). As the dissent explained, these terms are ‘generic and broad.’” Appellant’s Br. 40. Microsoft asserts that the context of the sentence confirms that it applies broadly to all embodiments of Kenoyer because it comes at the end of the written description “along with other general paragraphs that ‘indisputably apply to the entire disclosure, and are written in similar broad generic terms.’” *Id.* (quoting *57 IPR*, at *—, 2016 Pat. App. LEXIS 7571, at *42 (Cherry, A.P.J., dissenting)). Microsoft also argues that the teachings of Kenoyer, such as its statement that, “[i]n various embodiments, codecs may be implemented in software, hardware, or a combination of both,” Kenoyer, col. 5 ll. 8–10, would allow a POSA to understand that Kenoyer disclosed the use of program instructions to enable the performance of the relevant functions. Appellant’s Br. 41–42 (citing *57 IPR*, at *—, 2016 Pat. App. LEXIS 7571, at *40 (Cherry, A.P.J., dissenting)). Microsoft contends that the Board’s contrary findings are meritless and “not credible.” *Id.* at 43–45.

*12 Biscotti responds by arguing that the sentence in the specification does not link Kenoyer’s storage medium with Kenoyer’s instructions. Biscotti notes that Kenoyer’s specification is “imprecise” in its disclosure and that even the Board’s dissenting panel member stated during the oral hearing that the sentence “is poorly drafted.” Appellee’s Br. 55 (quoting J.A. 1982, l. 4 (internal quotation marks omitted)). Biscotti also points out that its expert explained to the Board that the sentence in the specification is best read, in context, as applying only to Figure 22, rather than the entire patent. *Id.* (citing J.A. 9373–76; J.A. 10144–46). Biscotti asserts that Microsoft’s reading of the sentence would create “numerous questions and ambiguities” that are avoided by Biscotti’s reading, and that, when questioned about these issues at his deposition, Microsoft’s expert responded, “one of ordinary skill in the art could, like, read about what the function was and make a decision.” Appellee’s Br. 58 (quoting J.A. 9875, ll. 11–22 (internal quotation marks omitted)). According to Biscotti, this testimony from Microsoft’s expert falls well below meeting Microsoft’s burden of proof that a POSA would “at once envisage” the claimed invention if the POSA would have to “read about what the

function was and make a decision.” *Id.* Biscotti finally argues that *Kennametal* and *Blue Calypso* do not help Microsoft because Microsoft’s reading of Kenoyer would result in “indiscriminate combinations of components and functions that can be cobbled together from passages found anywhere within Kenoyer’s lengthy specification,” such that a POSA could not “at once envisage” all of the combinations, including the combination patented in the ‘182 patent. *Id.* at 58–60.

On balance, the parties’ arguments presented the Board with a close question. As Microsoft notes, the specification’s three paragraphs between the summary of each step in Figure 22 and claim 1 use broad language that refers generally to “embodiments,” which might be interpreted as referring to all embodiments of the patent. *See* Kenoyer, col. 15 l. 21–col. 16 l. 2. The final paragraph also states that “[f]urther modifications and alternative embodiments of various aspects of *the invention* may be apparent to those skilled in the art in view of this description.” Kenoyer, col. 15 ll. 55–57 (emphasis added). The broad language of these three paragraphs without any reference to Figure 22 might imply that these paragraphs refer more generally to the embodiments throughout the patent.

But Biscotti’s reading also has merit. The first two paragraphs after the paragraph expressly describing Figure 22 use different wording—referring only to “embodiments”—than the last paragraph in the specification—referring to “embodiments” within the context of “*the invention*.” One therefore can validly read the last paragraph as referring more generally to the invention as a whole, since the specification specifically refers to the invention, while the previous two paragraphs refer only to the description of Figure 22. *See* Kenoyer, col. 15 l. 21–col. 16 l. 2.

The first part of the description for Figure 22 also states, “[i]t should be noted that in various embodiments [(*plural*)] of the methods described *below*, one or more of the elements described may be performed concurrently, in a different order than shown, or may be omitted entirely.” *Id.* col. 15 ll. 2–6 (emphasis added). This leads into a description of the block diagram of the method in Figure 22. *Id.* col. 15 ll. 8–20. The very next sentence after the description of the block diagram states that “[e]mbodiments [(*plural*)] of a subset or all (and portions or all) of the *above* may be implemented by

program instructions stored in a memory medium or carrier medium and executed by a processor.” *Id.* col. 15 ll. 21–24 (emphasis added). In context, the sentences both could refer to the description of the block diagram of Figure 22 to provide variations for performing the method, and both refer to embodiments thereof.

Although Microsoft's arguments are not unreasonable, we do not review this question de novo; anticipation is a question of fact, and we review the Board's findings for substantial evidence. *Kennametal*, 780 F.3d at 1381. As discussed above, the material in the disclosure lends itself to more than one reasonable interpretation. The Board explained that both sides proffered expert testimony regarding how a POSA would view these disclosures, and the Board considered and analyzed the expert testimony from each. Based on the evidence before it, the Board found that “Kenoyer's program-instructions sentence does not make sense as a disclosure blanketing all of the preceding 34 pages” and that the sentence “does not refer back specifically to the various other disclosures cited by [Microsoft].” 57 *IPR*, at *9, 2016 Pat. App. LEXIS 7571, at *26. Instead, the Board found that Biscotti's argument and evidence regarding the meaning of the sentence was “at least as persuasive as [Microsoft's] argument and evidence” such that Microsoft had failed to meet its burden of proof. *Id.* at *9, 2016 Pat. App. LEXIS 7571, at *27.

*13 The Board further explained that it “makes sense that a videoconferencing method would lend itself to implementation with program instructions,” and it “makes sense that the program-instructions sentence would refer specifically to the videoconferencing method disclosed” in the discussion of Figure 22. *Id.* The Board therefore “agree[d] with [Biscotti]” that Kenoyer's reference to “embodiments of the methods described below” and “[e]mbodiments of a subset or all (and portions or all) of the above” both refer to the description of Figure 22. *Id.* at *7, 2016 Pat. App. LEXIS 7571, at *27–28. The Board accordingly found that Microsoft had “not demonstrated by a preponderance of the evidence that Kenoyer's program-instructions sentence and various other cited portions disclose the claimed ‘storage medium’ with its four specific ‘instructions for,’ or that a person of ordinary skill in the art would ‘at once envisage’ a storage medium with the specific instructions claimed.” *Id.* at *10, 2016 Pat. App. LEXIS 7571, at *28–29.

The Board found further support for its conclusion in the fact that Kenoyer's alleged disclosures of a storage medium with instructions in accordance with the limitations of claim 6 “are unrelated to each other in [the] disclosure.” *Id.* at *10, 2016 Pat. App. LEXIS 7571, at *29. The disclosure therefore, at most, amounted to “distinct teachings that the artisan might somehow combine to achieve the claimed invention.” *Id.* at *10, 2016 Pat. App. LEXIS 7571, at *29–30 (quoting *Net MoneyIN*, 545 F.3d at 1369 (internal quotation marks omitted)). The Board also found that Microsoft had failed to provide “persuasive evidence that the disclosure would be understood by one of ordinary skill in the art to mean that the storage medium with program instructions and the functions performed in the various embodiments are used together in Kenoyer.” *Id.* at *10, 2016 Pat. App. LEXIS 7571, at *30. The Board therefore found that Kenoyer did not anticipate claim 6 of the '182 patent. *Id.*

As Biscotti correctly argued, “[h]owever ‘close’ certain factual questions may have been before the Board, the Board was entitled, at the very least, to credit Biscotti's evidence and its expert's view of Kenoyer's disclosure over Microsoft's, and to find that Microsoft failed to meet its burden of proof.” Appellee's Br. 51. The case, therefore, “cannot be a close case on appeal under the proper standard of review.” *Id.* “Whatever arguable merit there may be to Microsoft's reading of Kenoyer, it was certainly not compelled here.” *Id.*

Biscotti's argument properly aligns with our role as an appellate court that reviews the legal and factual determinations of a trial court or, in this instance, the Board. *See, e.g., Key Pharm. v. Hercon Labs. Corp.*, 161 F.3d 709, 715 (Fed. Cir. 1998) (noting that “the function of an appellate court is to correct errors committed at trial”). We do not duplicate the efforts of a trial court or the Board. We instead provide proper deference to the fact-finder below rather than reweigh factual determinations. *See, e.g., Anderson v. City of Bessemer City*, 470 U.S. 564, 573–74, 105 S.Ct. 1504, 84 L.Ed.2d 518 (1985) (“If the district court's account of the evidence is plausible in light of the record viewed in its entirety, the court of appeals may not reverse it even though convinced that had it been sitting as the trier of fact, it would have weighed the evidence differently.”); *Lavender v. Kurn*, 327 U.S. 645, 653, 66 S.Ct. 740, 90 L.Ed. 916 (1946) (“[T]he appellate court's function is exhausted when that evidentiary basis [to support a verdict] becomes

apparent, it being immaterial that the court might draw a contrary inference or feel that another conclusion is more reasonable.”).

Given the evidence before the Board and its underlying factual findings, we conclude that the Board's finding that Kenoyer did not anticipate claim 6 is supported by substantial evidence.

3. Claim 69

The primary dispute between the parties regarding claim 69 involves whether Kenoyer teaches the following limitation: “receiving, on the audiovisual input interface, a set-top box audiovisual stream from a set-top box, the set-top box audiovisual stream comprising a set-top box video stream and a set-top box audio stream.” ['182 patent](#), col. 38 ll. 1–4.

*14 Microsoft asserts that Kenoyer discloses this limitation in its teaching about an external codec with audio and video inputs coupled to and receiving audiovisual signals from a television set-top box. It explains that “Kenoyer introduces the codec as a device with functionality to process audio and video signals, and Kenoyer uses the term ‘codec’ that way consistently thereafter.” Appellant's Br. 46. Microsoft also argues that Kenoyer's Figure 5 provides a detailed view of an audiovisual input interface for an embodiment of external codec 309, *id.*, and that Kenoyer describes physical forms in which the codec might appear, *id.* at 46–47. According to Microsoft, these descriptions would allow a POSA to “reasonably understand” and “at once envisage” the functionality of the external codec and the arrangement of the set-top box coupled to an external codec as being read together. *Id.* at 47–48. Microsoft asserts that this case is similar to our decision in *Blue Calypso* because the prior art in this case similarly contemplates the combination of disclosed functionalities, and Kenoyer's failure to explain word-for-word that inputs on the external codec depicted in Figure 5 are also needed for and included on an external codec that is coupled to a set-top box does not negate Microsoft's argument because a POSA would at once envisage the combined features. *Id.* at 48–49.

According to Microsoft, the Board's holding was based on two reasons: (1) the Board thought Microsoft's reading improperly “combined separate embodiments to account

for the limitations of the claim” by putting together the inputs from Figure 5 with the subsequent set-top box disclosure of a pass-through external codec, *id.* at 49 (citing Kenoyer, Figure 5 and col. 10 ll. 25–30); and (2) the Board could not find requisite inputs or disclosures in Figures 7a and 7b, so Kenoyer could not anticipate, *id.* at 50 (citing *59 IPR*, at *—, 2016 Pat. App. LEXIS 7573, at *27). As to the first reason, Microsoft argues that it was allowed to rely on Kenoyer's description of audiovisual inputs in connection with an external codec and then refer to an external codec again without having to repeat the discussion of the same audiovisual inputs. *Id.* at 49. As to the second reason, Microsoft argues that it relied on the description of the standalone codec coupled with the set-top box for the codec functionality, so Figures 7a and 7b, which show a codec incorporated into a set-top box, are inapposite. *Id.* at 50.

Biscotti characterizes Microsoft's argument as (1) Kenoyer discloses a unitary concept of an external codec that performs the receiving function, and (2) all references in Kenoyer to a codec should be read together. Appellee's Br. 60. Biscotti argues that the Board correctly rejected that argument because the codecs disclosed in Kenoyer on which Microsoft relies “referred to distinct, largely incompatible embodiments.” *Id.* at 63. And Figures 3 and 5, which do use the same reference to a codec, related to a personal computer embodiment, as shown by Figure 3's appearance and by Figure 5's inclusion of ports (e.g., “VGA In” and “Microphone In”), that ordinarily are not used with set-top boxes. *Id.* Biscotti asserts that this case is similar to *Net MoneyIN*, where we held that the district court erred when it combined parts of separate protocols, which “invoke[d] the question of obviousness, not anticipation.” [545 F.3d at 1371](#).

Regarding Figures 7a and 7b, Biscotti notes that the Board addressed these figures because “Microsoft's petition referred explicitly to the codec of those figures in connection with the first ‘receiving’ step.” Appellee's Br. 63. The Board considered Microsoft's expert testimony regarding Figures 7a and 7b and the codec's “pass-through” function, and it found the argument and the testimony unpersuasive. *Id.* at 64 (citing *59 IPR*, at *—, 2016 Pat. App. LEXIS 7573, at *27). According to Biscotti, Microsoft's new argument that Figures 7a and 7b are “inapposite” merely confirms the Board's analysis.

Finally, Biscotti asserts that Microsoft has changed its argument on appeal from the argument that was presented to the Board in Microsoft's petition to institute the IPRs. *Id.* Biscotti argues that Microsoft has waived its new arguments by not presenting them to the Board. *Id.*

[11] As an initial matter, Microsoft did not present to the Board the full argument that it presents here on appeal. In its petition to institute the IPR, the extent of its analysis regarding the relevant limitation of claim 69 is as follows:

*15 Kenoyer discloses receiving audio and video from the set top box using the interface described above [Figure 5]. “The codec may also be in an independent housing that is coupled to the set-top box 705. The codec may act as a pass-through for the regular programming/games when a conference is not being held.” Kenoyer therefore shows [the limitation].

J.A. 306–07 (citations omitted). The citations provided by Microsoft are the line numbers for the quote in Kenoyer and paragraphs from Microsoft's expert report that refer to the same quoted language within the context of Figures 7a and 7b. J.A. 2266–67, 2281–82.

Microsoft's argument, therefore, generally referred to Figure 5 and then used the language in Kenoyer, col. 10 ll. 25–28, regarding the pass-through clause to support the anticipation of claim 69. This bare-bones allegation provided no information or argument as to how the interface of Figure 5 allows for connection to a set-top box or how a POSA would understand to use the codec described in Figure 5 along with, as Microsoft describes it, the figureless description of a codec that can be used in an independent housing and coupled to the set-top box.

Microsoft's brief on appeal is far more detailed and contains substantial new arguments regarding why it believes Kenoyer anticipates this limitation of claim 69. But, Microsoft needed to include those arguments in the petition to institute. Specifically, a petition must include:

The exhibit number of the supporting evidence relied upon to support the challenge and the relevance of the evidence to the challenge raised, including identifying specific portions of the evidence that support the challenge. The Board may exclude or give no

weight to the evidence where a party has failed to state its relevance or to identify specific portions of the evidence that support the challenge.

37 C.F.R. § 42.104(b)(5) (emphasis added). And, the general rule is that any argument not raised before the Board is waived on appeal. See *Redline Detection, LLC v. Star Envirotech, Inc.*, 811 F.3d 435, 450 (Fed. Cir. 2015). Microsoft not only failed to present these arguments in its petition, it never sought permission to present them to the Board during the course of the IPR.

[12] The Board found that Microsoft's description of Kenoyer did not explain how the interface of Figure 5, with the Microphone In (513), Alternate In (515), VGA In (503), and Alt Video In (507), refers to the codec described in column 10, lines 25–30, acting as a pass-through while coupled to a set-top box. *59 IPR*, at *—, 2016 Pat. App. LEXIS 7573, at *27–28. The Board explained that, with no direct link in Kenoyer to connect these descriptions of a codec, Microsoft's expert simply contended that a POSA “would understand Kenoyer as disclosing using such inputs to receive the regular programming/games because those inputs are capable of receiving video input from a set-top box.” *Id.* at *9, 2016 Pat. App. LEXIS 7573, at *28. The Board found this contention unpersuasive because Biscotti had introduced evidence that “cast substantial doubt” regarding whether a POSA would have considered the interface connections appropriate for connecting with a set-top box. *Id.* at *— —, 2016 Pat. App. LEXIS 7573, at *28–29. Biscotti introduced evidence that the interface of Figure 5 crossed over with the description of Figure 3 (both are identified with the same numeric identifier, (309)), which was a set-up in which the codec was connected to a computer. J.A. 1053. Biscotti also argued that a POSA would understand that neither of the inputs VGA In or Alt Video In would be used with a set-top box because they are used for connecting computers and monitors, not for the transmission of a cable or satellite signal. J.A. 1053. There also was no disclosure of an audio input interface for the set-top box because the Microphone In would be used for a microphone, and a POSA would understand the Alternate In, which Kenoyer describes as input for a camera or microphone array—not a set-top box—would not be used for a set-top box. J.A. 1054. Microsoft, meanwhile, provided no explanation in its petition as to how the interface of Figure 5 would be compatible with a set-top box and the codec described in Kenoyer, column 10 lines 25–28.

*16 The Board's factual findings in favor of Biscotti are supported by substantial evidence, and any supplemental argument seeking to refute those findings on appeal has been waived. We therefore affirm the Board's finding that Microsoft failed to prove claim 69 is anticipated by Kenoyer.

C. The Board's "Construction" of "Set-Top Box"

Microsoft argues that the Board did not use the broadest reasonable interpretation of the term "set-top box," which Microsoft asserts is defined in the '182 patent as "any device that can provide video tuning, decryption *and/or* decoding functionality, especially as that functionality relates to reception of broadcast, cable, and/or satellite television signals." Appellant's Br. 51 (quoting '182 patent, col. 9 ll. 23–26 (internal quotation marks omitted)). Microsoft contends that this broad definition includes televisions and computers. *Id.* at 51–52. Because the Board allegedly limited Kenoyer according to the meaning of "set-top box" provided in Kenoyer rather than applying the broader definition of "set-top box" from the '182 patent to the teachings of Kenoyer, Microsoft argues that the Board erred in its analysis of the scope of Kenoyer's teachings. According to Microsoft, this error by the Board was prejudicial to its anticipation case because allowing a computer to be a "set-top box" would result in the conclusion that Kenoyer's description of Figures 3 and 5 anticipates claim 69. *Id.* at 52–53. Microsoft also asserts that using the definition of "set-top box" from the '182 patent would have changed the Board's analysis regarding claim 6 because the new definition of set-top box would allow for the program-instructions sentence in the specification to anticipate claim 6, even if the sentence referred only to Figure 22. *Id.* at 53.

Biscotti argues that Microsoft's claim construction argument is "an inapt repackaging of its disagreement with the Board's factual findings on anticipation" and a mischaracterization of the Board's decisions. Appellee's Br. 66. Biscotti argues that the Board's decisions in all three IPRs did not rely on any construction of any term, much less "set-top box." *Id.* Biscotti notes that "set-top box" does not appear at all in the storage medium and instructions limitations of claim 6, so any construction of "set-top box" would have no impact on the Board's decision for claim 6. *Id.* at 67–68.

Biscotti also contends that the Board's decision turned on "the interrelation between different parts of Kenoyer's disclosure—i.e., whether it was proper to combine those parts for anticipation purposes in the first place, as Microsoft urged." *Id.* at 68. Biscotti argues that the Board was unpersuaded that a POSA would "at once envisage" the steps of claim 69 by "combining scattered passages of Kenoyer in the manner Microsoft and its expert urged." *Id.* at 69.

[13] Microsoft's argument that a computer could act as a set-top box could be relevant to the analysis of claim 69, especially given Biscotti's argument that Microsoft failed to prove a codec connected to a set-top box because the interface of Figure 5 is shown in Figure 3 to connect to a computer. Although Microsoft argues that a computer might be able to have the functionality of a set-top box under what it alleges is the patent's definition of set-top box, Microsoft fails to explain how a computer, especially the computer in Kenoyer, would receive broadcast, cable, or satellite television signals. Microsoft provides no explanation as to how a POSA would understand the computer in Kenoyer to be a set-top box with the special functionality required by Microsoft's definition.¹

¹ The dissent faults our conclusion that Microsoft fails to explain how Kenoyer's computer would receive broadcast, cable, or satellite television signals. Dissent at 17. But, as described above, our conclusions were drawn in the context of analyzing Microsoft's argument that the Board erred in its interpretation of "set-top box." In particular, Microsoft has not shown how the computer in Kenoyer would qualify as a set-top box under its own definition of that term. As described above, that failure is fatal to Microsoft's claim of error.

*17 Even if Microsoft had overcome that hurdle, the error still would not be prejudicial because Microsoft waived the arguments regarding claim 69 that relate to this construction. In other words, the Board's decision hinged on factors that were not affected by an allegedly erroneous construction of "set-top box." Although some of the reasoning provided by the Board might be affected by use of Microsoft's construction of set-top box—like the Board's discussion of Figure 5 and Figure 3—there are other bases for the Board's decision that would not change and which suffice to support its conclusions.

D. Obviousness of the Dependent Claims

According to Microsoft, the Board erred in its obviousness analysis for the same reasons it erred in its anticipation analysis because the Board relied on the same reading of Kenoyer without conducting a separate obviousness analysis. As Biscotti points out, “the parties do not dispute that if the Court affirms or vacates the Board's rulings regarding anticipation of claim 6, it should do the same with respect to the Board's rulings on obviousness of claims 22, 36, 37, 42, 44, and 45.” Appellee's Br. 70.

As described above, the Board's findings as to claims 6 and 69 are supported by substantial evidence. Because Microsoft does not argue separately that the Board erred in its obviousness analysis, we also affirm the Board's obviousness holdings.

III. CONCLUSION

For the foregoing reasons, we find that the Board's decisions are supported by substantial evidence. We therefore affirm the Board's decision that Microsoft failed to prove invalidity by a preponderance of the evidence in each of the IPRs on appeal.

AFFIRMED

[Newman](#), Circuit Judge, dissenting.

I respectfully dissent. The Kenoyer reference describes the same invention that is claimed in claims 6 and 69, the only claims of Biscotti's '182 patent that are reviewed by the court. These claims recite no new components or functions or technology; they directly read on, and are anticipated by, the prior art system described in the Kenoyer reference.

As I shall illustrate, every claim clause is shown in Kenoyer. Every claim component was previously known, and performs the same function in the same way in the same combination. The claims at issue are “anticipated,” under the most rigorous application of the law of anticipation.

The claims on appeal recite no distinction from the Kenoyer videoconferencing system, as to any component or function or arrangement. Microsoft states, without contradiction from either Biscotti or the court:

The '182 patent neither describes nor claims any new components, software, programming steps, or anything else not found in existing systems. Nor does it describe or claim any arrangement or configuration of components or functionalities that reduces the size, complexity, or cost, or improves the quality, of existing videoconferencing systems.

Microsoft Br. 13. My colleagues on this panel search for distinctions that are neither described nor claimed, contrary to the law of anticipation.

Kenoyer teaches the same conferencing system as in the '182 patent

Claim 6 is the broadest claim for the '182 patent's conferencing system, in which known audio and video components provide inputs to a computer that receives and stores and transmits the information to participants in the conference. Kenoyer describes the same system, and shows the same components combined in the same way. As stated in *Kemmetal, Inc. v. Ingersoll Cutting Tool Co.*, 780 F.3d 1376, 1381 (Fed. Cir. 2015), a reference anticipates a claim if it discloses all the claimed limitations “arranged or combined in the same way as in the claim,” quoting *Wm. Wrigley Jr. Co. v. Cadbury Adams USA LLC*, 683 F.3d 1356, 1361 (Fed. Cir. 2012).

*18 The '182 patent states that it achieves improved “reliability,” but Biscotti does not dispute that any such improvement is due to known improvement in the known audio and video components—for example, improved cameras and microphones. No improvement by Biscotti is described in the '182 patent or included in the '182 claims. The '182 claims are broadly stated, whereas the court's analysis is directed to aspects that are not limitations to the claims.

Following is a clause-by-clause review of claim 6, the only system claim discussed by the panel majority. (bracketed numbers added):

6. **[1]** A video communication system, comprising:
- [2]** a first video communication device, comprising:
 - [3]** a video input interface to receive video input from a set-top box;
 - [4]** an audio input interface to receive audio input from the set-top box;
 - [5]** a video output interface to provide video output to a video display device;
 - [6]** an audio output interface to provide audio output to an audio receiver;
 - [7]** a video capture device to capture video;
 - [8]** an audio capture device to capture audio;
 - [9]** a network interface;
 - [10]** at least one processor; and
 - [11]** a storage medium in communication with the at least one processor, the storage medium having encoded thereon a set of instructions executable by the at least one processor to control operation of the first video communication device, the set of instructions comprising:
 - [i]** instructions for controlling the video capture device to capture a captured video stream;
 - [ii]** instructions for controlling the audio capture device to capture a captured audio stream;
 - [iii]** instructions for encoding the captured video stream and the captured audio stream to produce a series of data packets; and
 - [iv]** instructions for transmitting the series of data packets on the network interface for reception by a second video communication device.

Claim clause [1]

Clause [1] is an introductory clause, and its statement of “a video communication system” matches the Kenoyer

patent's title of “Integrated Videoconferencing System.” The '182 patent recognizes that such systems were previously known, and criticizes current products as expensive professional-grade systems, and error-prone systems based on a personal computer with far from optimal call quality. The '182 patent criticizes the cost of video phones and their small screens, and thus “fail[ure] to provide an inclusive family video calling experience.” '182 patent, col. 1, l. 46–col. 2, l. 6.

The Kenoyer reference was not cited in the PTO examination of the '182 patent. Kenoyer describes the same audiovideo conferencing system in the same terms as in the '182 patent:

Videoconferencing may be used to allow two or more participants at remote locations to communicate using both video and audio. Each participant location may include a videoconferencing system for video/audio communication with other participants. Each videoconferencing system may include a camera and microphone to collect video and audio from a first or local participant to send to another (remote) participant.... Each videoconferencing system may also be coupled to a computer system to allow additional functionality into the videoconference....

Kenoyer, col. 1, ll. 25–36. This recitation itself anticipates claim 6, for claim 6 is written in broad terms, and does not limit these components and their functions. Figure 1 of Kenoyer is described as follows:

Videoconferencing system 100 comprises a plurality of participant locations or endpoints. FIG. 1 illustrates an exemplary embodiment of a videoconferencing system 100 which may include a network 101, endpoints 103A–103H (e.g., audio and/or videoconferencing systems), gateways 130A–130B, a service provider 108 (e.g., a multipoint

control unit (MCU)), a public switched telephone network (PSTN) 120, conference units 105A–105D, and plain old telephone system (POTS) telephones 106A–106B. Endpoints 103C and 103D–103H may be coupled to network 101 via gateways 130A and 130B, respectively....

*19 Kenoyer, col. 3, l. 63–col. 4, l. 6. All of the elements of claim 6 are in Kenoyer's Figure 1, performing the same function and in the same breadth as in claim 6.

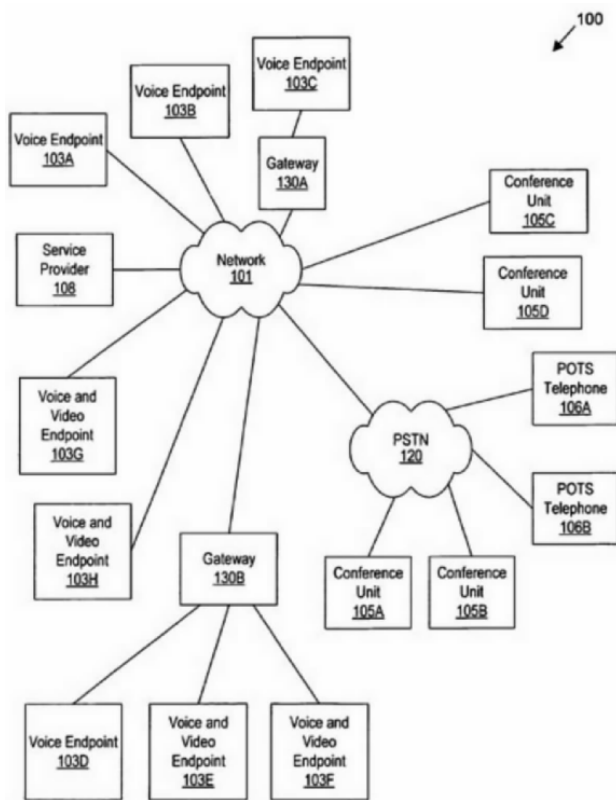

FIG. 1

The system depicted in the Kenoyer Figures and description anticipates claim 6, for the elements of claim 6 match the elements in the Kenoyer reference.

Claim clause [2]

It is not disputed that Kenoyer shows what the '182 patent calls a “first video communication device.” Kenoyer recites “various video devices” such as “monitors, projectors, displays, televisions, video output devices, video input devices, cameras, etc.,” col. 4, ll. 44–46, and

discusses the video function and known video devices that perform this function. For example, Kenoyer states:

In some embodiments, the participant location may include a camera 204 (e.g., an HD [high definition] camera) for acquiring images (e.g., of participant 214) of the participant location. Other cameras are also contemplated. The participant location may also include a display 201 (e.g., an HDTV display). Images acquired by the camera 204 may be displayed locally on the display 201 and may also be encoded and transmitted to other participant locations in the videoconference.

Kenoyer, col. 5, ll. 36–43 (referring to Figure 2). Kenoyer states that the video communication may be accompanied by “various audio devices” such as “microphones, audio input devices, speakers, audio output devices, telephones, speaker telephones, etc.” Kenoyer, col. 4, ll. 41–44.

The breadth of the Kenoyer disclosure is matched by the breadth of disclosure in the '182 patent, which states that “a high-definition video camera is but one example” of a “video capture device,” and examples of an “audio capture device” are a “microphone or microphone array.” '182 patent, col. 2, ll. 61–66.

It is not disputed that the '182 patent clauses [1] and [2] recite no distinction from Kenoyer.

Claim clauses [3] and [4]

This pair of clauses includes the “set-top box,” a component of both the Kenoyer and the '182 systems. The '182 patent defines the set-top box as “any device that can provide video tuning, decryption and/or decoding functionality, especially as that functionality relates to reception of broadcast, cable, and/or satellite television signals.” '182 patent, col. 9, ll. 22–26.

Kenoyer describes the set-top box as “e.g., a cable box, satellite box, or gaming module,” col. 1, ll. 62–63, and states that:

The codec's audio and video processing may be incorporated in the set-top box and/or may be distributed (e.g., to other devices through a cable coupling the devices to the set-top box). The set-top box may be coupled to the different components of the videoconferencing system including the camera, speakers, microphones, and display.

Kenoyer, col. 1, l. 65–col. 2, l. 3.

As in the '182 patent, Kenoyer describes a “video input interface” that “receive[s] video input from a set-top box,” as in clause [3]; and an “audio input interface” to “receive audio input from a set-top box,” as in clause [4]. These components and their functions are described in the same way in Kenoyer and the '182 patent. No distinction is shown between the set-top box as set forth in clauses [3] and [4], and the Kenoyer set-top box.

Claim clauses [5] and [6]

*20 The next pair of clauses recites that the “video output interface” is provided to a “video display device,” clause [5]; and the “audio output interface” is provided to an “audio receiver,” clause [6]. The '182 patent claims these devices and functions in broad terms and describes their conduct using known components, stating, for example:

Merely by way of example, the input audio interface 425 and/or output audio interface 435 may comprise a set of RCA analog jacks, a fiber optic and/or coaxial digital interface and/or the like. Similarly the input video interface 420 and/or output video interface 430 may be implemented as an analog composite, component, S-video, and/or VGA interface, and/or as a digital component interface and/or digital visual interface (“DVI”)....

'182 patent, col. 10, ll. 24–31 (referring to Figure 4).

Kenoyer too provides a broad teaching of audio and video inputs and outputs. For example, discussing the video display, Kenoyer states:

The videoconferencing system may support HD [high-definition] capabilities. The term “high resolution” includes displays with resolution of 1280x720 pixels and higher. In one embodiment, high-definition resolution may comprise 1280x720 progressive scans ... [t]hus, an embodiment of the present invention may comprise a videoconferencing system with HD “e.g. similar to HDTV” display capabilities using network infrastructures with bandwidths T1 capability or less.

Kenoyer, col. 5, ll. 17–26. Kenoyer also recites the computer connections, and the codec interface and coupling, for the video display output:

The codec 309 may also place an interface on part of the computer system display output. The computer system 355 may be coupled directly to the display 305 and may receive a video signal to display from the codec 309.

Kenoyer, col. 9, ll. 5–8 (referring to Figures 3 and 5). Kenoyer discusses various embodiments; for example:

In some embodiments, the MCVCS 300 may support dual streams for sharing PC content during a videoconference (e.g., standards based (H. 239) dual streaming for real-time collaboration in HD). Media shared through the MCVCS 300 may include documents, presentations, and PC screens. Other media may also be shared. The MCVCS 300 may support IP [Internet Protocol] to integrated services digital network (ISDN) connectivity.

Kenoyer, col. 9, ll. 35–41 (referring to Figures 3 and 5). The '182 patent states:

The video communication device 105 of FIG. 5 also includes both HDMI [high-definition multimedia interface] input 520 and output 530 interfaces as well as a set of analog audio and video interfaces 525, 535 for input and output, respectively. The HDMI input interface 520 may be configured to receive a high-definition audiovisual input from the STB [set-top box], while the HDMI output interface 530 may be configured to provide high-definition audiovisual output for display on a HDTV [high-definition television].

'182 patent, col. 14, ll. 9–16 (referring to Figure 5).

It is not disputed that Kenoyer shows components and functions within the scope of clauses [5] and [6].

Claim clauses [7] and [8]

These clauses recite the '182 system's "video capture device," clause [7]; and the "audio capture device," clause [8]. The '182 patent describes these functions broadly; for example, at col. 2, ll. 61–66:

The video communication device might further comprise a video capture device (of which a high-definition video camera is but one example) to capture a captured video stream and/or an audio capture device (of which a microphone or microphone array might be examples) to capture a captured audio stream.

*21 Kenoyer too describes these functions broadly, stating that "local video and audio may be captured," col. 15, ll. 8–10, and "local video and audio may be processed in codec 309 for transmission to a remote conference site," col. 15, ll. 11–12. Kenoyer states at col. 7, l. 66–col. 8, l. 4:

The codec 309 may receive local signals from the camera 303 and microphones 319 for transmission to a remote conference site. The codec 309 may compress signals for transmission and decompress received signals for distribution to the display 305 and/or speakers 311.

It is not disputed that Kenoyer describes the same functions and components as set forth in clauses [7] and [8]. Kenoyer's Figure 22, reproduced at Maj. Op. 13, shows the functions of these and the other claim clauses.

The breadth of the audio and video capture and processing clauses [7] and [8] is illustrated throughout the Kenoyer disclosure.

Claim clause [9]

Clause [9] recites a "network interface," described in the '182 patent as an "integrated wireless local area network," col. 5, l. 34; a "personal computer 130 programmed with a chat application 135, such as SKYPE, MSN MESSENGER, and/or the like," col. 6, ll. 26–28; and "[i]n a set of embodiments, the communication server 205 communicates with the video communication devices 105 over the Internet," col. 6, ll. 51–53.

Kenoyer too describes connection to networks, reciting various possible connections. Kenoyer states at col. 1, ll. 51–53:

The MCVCS [multi-component videoconferencing system] may send/receive signals through a network coupled to the computer system or to one of the MCVCS components.

At col. 8, ll. 11–14, Kenoyer states:

For example, the network connection 351 may be from an IP [Internet Protocol] link 371 coupled to the computer system 355 from an external network (other types of links are also contemplated).

Discussing networks and referring to Figure 1, Kenoyer states at col. 4, ll. 17–27:

In some embodiments, endpoints 103A–103H, gateways 130A–130B, conference units 105C–105D, and service provider 108 may each include various wireless or wired communication devices that implement various types of communication, such as wired Ethernet, wireless Ethernet (e.g., IEEE 802.11), IEEE 802.16, paging logic, RF (radio frequency) communication logic, a modem, a digital subscriber line (DSL) device, a cable (television) modem, an ISDN [Integrated Services Digital Network] device, an ATM (asynchronous transfer mode) device, a satellite transceiver device, a parallel or serial port bus interface, and/or other type of communication device or method.

Kenoyer also describes conversion to digital signals for transmission over digital networks, at col. 5, ll. 4–7:

For example, communication applications may use codecs to convert an analog signal to a digital signal for transmitting over various digital networks (e.g., network 101, PSTN 120, the Internet, etc.)

Kenoyer also describes ports for connection of signals involving video equipment and network transmission, stating, for example, at col. 9, ll. 9–19:

In some embodiments, ports may also be included for video output (e.g., VGA–Out 505 and Alternate Video–Out 509). These ports may be used to output the video signal from the codec 309 to the display 305. Another port(s) may be included to receive/transmit network signals (e.g., an Ethernet port such as Internet Protocol (IP) port 501). Additional ports (e.g., camera in

511, microphone-in 513, speaker-out 517, etc.) may also be used to receive/send signals to/from various equipment coupled to the codec 309. The camera and microphone array signals may be sent to the codec 309 through one connection (e.g., alternate input 315).

*22 Again, it is not disputed that both the '182 patent and Kenoyer describe various networks and their use to transmit audio and video information in the conferencing system to which both the '182 patent and Kenoyer are directed. The “network” clause [9] is plainly anticipated.

Claim clause [10]

Clause [10] recites “at least one processor.” Both the '182 patent and Kenoyer state the use of a computer/processor programmed to manage the conferencing system. The '182 patent refers to “a dedicated video processor and/or digital signal processor (‘DSP’),” col. 9, l. 67–col. 10, l. 1, and states at col. 10, ll. 1–4:

Merely by way of example, the DM365 digital media processor from TEXAS INSTRUMENTS may be used as the processor 405 in one embodiment.

The '182 patent uses known computerized equipment for its known functions, and Kenoyer does the same. Kenoyer states at col. 15, ll. 50–54:

For example, the memory medium may store one or more programs that are executable to perform the methods described herein. The memory medium may also store operating system software, as well as other software for operation of the computer system.

Kenoyer states at col. 5, ll. 8–12:

In various embodiments, codecs may be implemented in software, hardware, or a combination of both. Some codecs for computer video and/or audio may include MPEG,

Indeo™, and Cinepak™, among others.

Kenoyer also describes computer connections over a network, stating at col. 15, ll. 37–41:

In addition, the memory medium may be located in a first computer in which the programs are executed, or may be located in a second different computer that connects to the first computer over a network, such as the Internet.

Again, it is not disputed that Kenoyer shows “at least one processor,” as in clause [10].

Claim clause [11]

Clause [11] recites a “storage medium” that encodes “instructions executable by the at least one processor” to operate the system. The '182 patent describes a storage medium such as an encoded hard drive or a RAM [random access memory], e.g., at col. 3, ll. 9–13:

In an aspect, the video communication device also includes a storage medium (e.g., a hard drive, DRAM, flash RAM, etc.) on which is encoded (perhaps among other data) instructions executable by the processor(s) to control operation of the video communication device.

Kenoyer too describes a storage medium:

program instructions stored in a memory medium or carrier medium and executed by a processor.

Kenoyer, col. 15, ll. 22–24. Kenoyer describes various memory and storage devices, stating at col. 15, ll. 24–35:

A memory medium may include any of various types of memory devices or storage devices ... a computer system memory or random access memory such as Dynamic Random Access Memory (DRAM), Double Data Rate Random Access Memory (DDR RAM), Static Random

Access Memory (SRAM), Extended Data Out Random Access Memory (EDO RAM), Rambus Random Access Memory (RAM), etc.; or a non-volatile memory such as a magnetic media, e.g., a hard drive, or optical storage.

The panel majority's holding that Kenoyer does not describe a “storage medium” is contrary to Kenoyer's extensive disclosure. Kenoyer anticipates the limitations of the introductory section of clause [11], as well as the four subclauses.

Subclauses [i], [ii], [iii], and [iv]

*23 These subclauses elaborate on the clause [11] processor instructions. The first two subclauses recite that the first video communication device is controlled by instructions for controlling the video capture [i] and the audio capture [ii] devices. Subclause [iii] states that there are instructions to encode the video and audio streams to produce data packets, and subclause [iv] states that instructions send the data packets to a second communications device via a network.

Kenoyer too shows a programmed computer that instructs on the subject matter of subclauses [i], [ii], [iii], and [iv], showing capture of the video stream, capture of the audio stream, encoding the information, and transmitting the data via a network. The panel majority states that Kenoyer does not teach that its system is run by “program instructions,” stating “that Microsoft had failed to provide ‘persuasive evidence that the disclosure would be understood by one of ordinary skill in the art to mean that the storage medium with program instructions and the functions performed in the various embodiments are used together in Kenoyer.’ ” Maj. Op. at 32–33. This is contrary to the entirety of Kenoyer, for throughout Kenoyer its system is shown as controlled by a programmed computer.

Kenoyer describes its computerized processing and transmission, stating, for example, that “local video and audio may be processed in codec 309 for transmission to a remote conference site,” col. 15, ll. 11–12. Kenoyer describes the encoding of signals into data packets for transmission, col. 8, ll. 10–14; col. 4, l. 66–col. 5, l. 12, and shows all of these operations managed by a

programmed computer, including Figures depicting the system components.

For example, Kenoyer Figure 7 illustrates the components and their combination for videoconferencing, managed by a set-top box in which “[t]he processing (e.g., audio and video processing) may be incorporated.” Kenoyer, col. 10, ll. 12–13. Kenoyer describes Figure 7a as showing a multi-component videoconferencing system (MCVCS) where:

the codec functionality may be incorporated in a set-top box 705 (e.g., a cable box). A camera 704 may be included on top of a display 701 coupled to the set-top box 705 (or placed on the set-top box 705). The processing (e.g., audio and video processing) may be incorporated in the set-top box 705 and/or may be distributed (e.g., to other devices through a cable coupling the devices to the set-top box 705). The set-top box 705 may be coupled to the different components of the MCVCS 700 including the camera 704, speakers 703, microphones, and display.

Kenoyer, col. 10, ll. 8–18. Kenoyer also describes the ports in Figure 7b, and states that:

The set-top box 705 may include a camera port 709 (e.g., for an HD camera). The set-top box 705 may also include video ports (e.g., S-Video port 711), audio ports (e.g., audio ports 713a-ib), and cable port 715, among others. The set-top box 705 may also communicate with components in the conference through wireless communications.

Col. 11, ll. 1–6. Kenoyer Figures 7a and 7b:

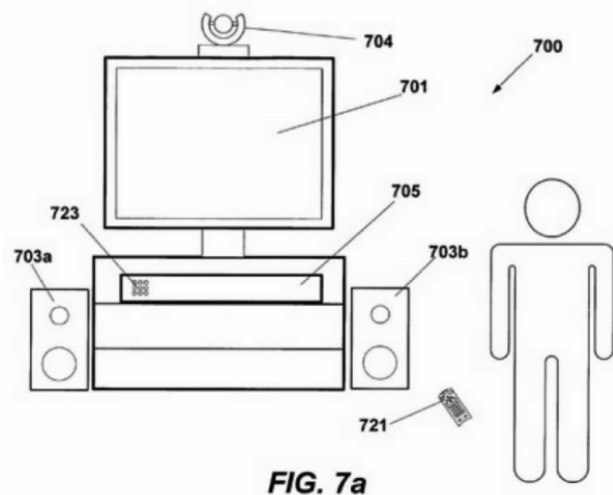

FIG. 7a

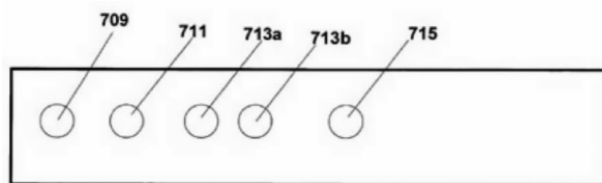

FIG. 7b

My colleagues misperceive the law of anticipation, for the question is whether the prior art shows the claimed subject matter—as indeed it does. It is not disputed that all of the elements of claim 6 are shown in Kenoyer, performing the same functions and combined in the same way. Kenoyer does not present “multiple, distinct teachings that the artisan might somehow combine to achieve the claimed invention,” as my colleagues propose. The claimed elements are not “somehow” combined—they are explicitly combined in Kenoyer, to provide the same conferencing system as in claim 6. To anticipate, a reference need disclose no more than is claimed in the challenged invention. *Iovate Health Scis., Inc. v. Bio-Engineered Supplements & Nutrition, Inc.*, 586 F.3d 1376, 1382 (Fed. Cir. 2009). It is incorrect to criticize the reference for the breadth of its disclosure, when the claims at issue are comparably broad.

*24 Contrary to the law of anticipation—for it is apparent that all of the Claim 6 clauses and subclauses are anticipated—my colleagues reason that “Microsoft fails to explain how a computer, especially the computer in Kenoyer, would receive broadcast, cable, or satellite television signals.” Maj. Op. at 40. However, neither does Biscotti explain how the computer in the '182 patent would receive broadcast, cable, or satellite television

signals. Neither Biscotti nor Kenoyer purports to have invented broadcast, cable, or satellite television signals, or to have invented the mechanism whereby a programmed computer processes audio and video signals by broadcast, cable, or satellite transmission.¹ The '182 patent and the Kenoyer reference both treat such signals as known technology.

¹ The panel majority states that my criticism is unwarranted, and that the majority raised this aspect only in connection with the set-top box. Maj. Op. at 40–41, n.1. This does not resolve the concern that the majority appears to hold that known technological information must be presented in full scientific detail, contrary to, e.g., *Falko–Gunter Falkner v. Inglis*, 448 F.3d 1357, 1368 (Fed. Cir. 2006) (the “forced recitation of known sequences ... would only add unnecessary bulk to the specification”).

The court states that Kenoyer teaches only “a mere catalog of separate parts,” and that Kenoyer simply “cobbled together” unrelated components “disconnected” from the videoconferencing system of the '182 patent. Maj. Op. at 22, 28, 30. This ignores the entire disclosure of Kenoyer. Both Kenoyer and the '182 patent describe the same system in the same terms, reciting the various known audio and video communication devices and their use in the same videoconferencing system. The entirety of Kenoyer is directed to videoconferencing by way of an

audio-video system that matches the '182 system. Kenoyer shows all of the components and functions of claim 6, in the same arrangement. Anticipation is plain.²

² Method claim 69 is based on the same specification, is subject to the same prior art, the same analysis, and the same conclusion.

The law of anticipation is clearly met, for on any view of Kenoyer, Kenoyer “sufficiently describe[d] the claimed invention to have placed the public in possession of it.” *In re Donohue*, 766 F.2d 531, 533 & n.7 (Fed. Cir. 1985). See generally *Kennametal*, 780 F.3d at 1381 (“However, a reference can anticipate a claim even if it ‘d[oes] not expressly spell out’ all the limitations arranged or combined as in the claim, if a person of skill in the art, reading the reference, would ‘at once envisage’ the claimed arrangement or combination.” (quoting *In re Petering*, 301 F.2d 676, 681 (CCPA 1962))). Kenoyer shows the same components, having the same function, combined in the same way for the same purpose. Substantial evidence does not support the panel majority's ruling that the '182 claims are not anticipated.

All Citations

--- F.3d ----, 2017 WL 6613262